

DCU_User Manual_EN V1.0

Release Notes

This document records the changes related to DCU User Manual.



Version	Update Date	Changes of Contents
V1.0	2024-11-25	Initial Version

Read before using

This manual is valid for the following battery models:

- DCU1000
- P1000

The following security symbols are used in this manual. Before installing or operating the system, familiarize yourself with these symbols and their meanings.

Identification	Explanation
	Danger: Danger indicates a dangerous situation that may cause fatal electric shock, other serious personal injury, or fire danger.
	Warning: Warnings indicate instructions that must be fully understood and followed to avoid potential safety hazards, including equipment damage or personal injury.
	Note: Notes indicate that the described operation should not be performed. Before continuing, readers should stop using and fully understand the explained operation.

Read the manual and other related documents before any work on the battery is carried out. Documents must be stored carefully and be available at all times. All

rights to the content of this manual are owned by TSUN Co., Ltd. (hereinafter "TSUN"). This document cannot be modified, distributed, reproduced or published in any form or by any means without prior written permission from TSUN. Content may be periodically updated or revised due to product development. The information in this manual is subject to change without notice. The latest manual can be acquired at www.tsun-ess.com.

Safety Instructions

1. Please store this product in a cool and dry place and Do not use this product near any fire.
2. Do not soak this product in water. It is not recommended to use this product in any rain or humid environment.
3. Do not use this product in any flammable, explosive or corrosive environment such as gasoline, gas and chemical agent, otherwise, your safety may be endangered.
 - Be sure to operate this product all the time in accordance with regulations, instructions and signs in an environment where explosion may occur.
 - Do not store any flammable liquids, gases or explosives in a case containing this product.
4. Do not use this product in any strong electrostatic or strong magnetic field environment.
5. Do not disassemble or puncture this product with any sharp object in any way.
6. Do not use wires or other metal objects for connection without permission, so as not to cause short circuit of this product.
7. Do not use unofficially provided components or accessories.
8. When using the product, strictly follow the ambient temperature specifications in this user manual. High temperatures may cause the battery to ignite or even explode. Low temperatures may significantly reduce product performance or even cause it to stop working.
9. Do not pile any other heavy object on.
10. Do not use this product in any strong electrostatic or strong magnetic field environment
11. Do not disassemble or puncture this product with any sharp object in any way.
12. Do not use wires or other metal objects for connection without permission, so as not to cause short circuits of this product.
13. Do not use any parts or accessories unofficially supplied.
14. When using this product, please strictly follow the environment temperature for service as specified in this User Manual. If the temperature is too high, the battery may catch fire or even explode; if the temperature is too low, the performance of this

product will be seriously reduced and may even stop working.

15. Do not pile any other heavy objects on this product.
16. Please avoid impact, fall or violent vibration, and in case of serious external impact, please immediately turn off the power and stop using this product. Please fix this product properly during transportation to avoid vibration and impact. It is recommended to use the original packaging for long-distance transportation.
17. If this product accidentally falls into water in the process of using, please keep it in a safe open area and Do Not get close to this product before it is dried in air. The dried product should be not reused but properly disposed of with the method specified in the section of "Waste" below. If this product caught fire, please use suitable extinguishing media in the following recommended order: water or water mist, sand, fire blanket, dry powder and carbon dioxide fire extinguisher.
18. In case of any dirt on the interface of this product, please wipe it clean with a dry cloth.
19. Please place this product carefully to prevent damage caused by dumping. If this product is seriously damaged after dumping, please shut down immediately, place the battery in an open area away from combustibles or people, and scrap it according to local laws and regulations.
20. Please store this product out of reach of children and pets to avoid potential safety hazards.
21. If water is found inside this product, please Do not power on for use again. Please take measures against electric shock before touching this product. Please stand still in a safe and waterproof open area immediately, and contact the customer service immediately.
22. This product is not recommended to supply power to medical emergency equipment related to personal safety.
23. Electromagnetic fields will inevitably be generated when power products are used, which may affect the normal operation of implantable medical devices or personal medical devices, such as pacemakers, cochlear implants, hearing aids, defibrillators and so on. If these medical devices are used, please consult their manufacturers about restrictions on their use, so as to keep the safe distance between this product and any implanted medical devices (such as pacemakers, cochlear implants, hearing aids, defibrillators, etc.) when working.
24. When such device is installed, the household electrical wiring can only be modified by trained professionals.
25. Please be sure to use the cable originated from us. When disconnecting the cable, if the plug has threads, please unscrew the nut before disconnecting the cable. Do not operate this product with damaged cables.

What's in the Box

DCU1000

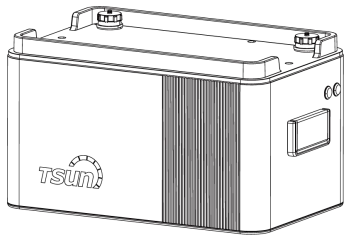
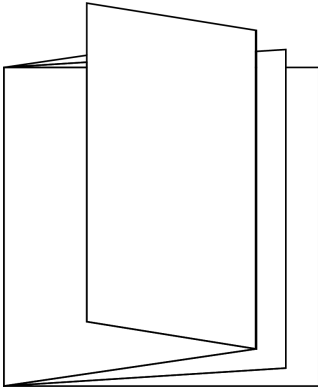
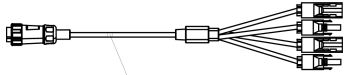
 A rectangular DCU1000 device with a handle on the right side and a 'TSUN' logo on the front.	 A stack of three white rectangular sheets representing a quick guide.	 A PV connecting cable with a blue connector on one end and multiple connectors on the other.
DCU1000	Quick guide	PV Connecting Cable (Blue connector)

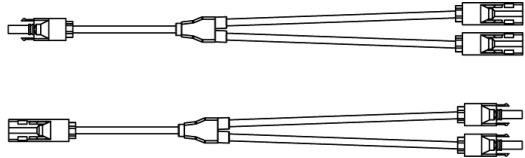
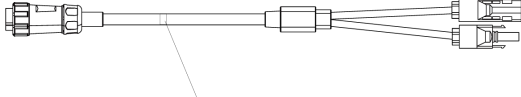
 Two microinverter 'Y' connecting cables, each with a single connector on one end and two connectors on the other.	 A microinverter cable with a black connector on one end and multiple connectors on the other.
Microinverter "Y" Connecting Cable	Microinverter Cable (Black connector)

P1000 (Optional accessories, not included in DCU1000 package)

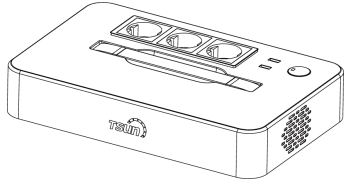
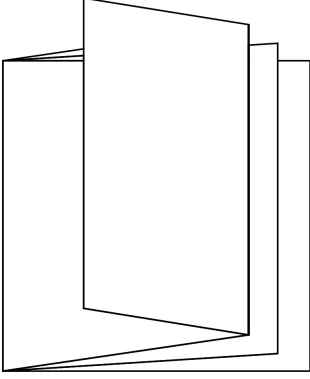
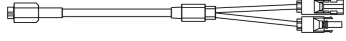
		
P1000	Quick guide	PV Connecting Cable

What's DC COUPLED UNIT(DCU)

DCU1000 is a key component of the plug&play storage system or micro storage system, it integrates both DC to DC inverter(pv charge and battery discharge function) and battery pack. DC Coupled Unit, which is connected between PV modules and balcony microinverter, can store excess electrical energy in the battery and discharge it when needed.

This solution, PV Module + DCU+ Balcony microinverter, is typically used as a micro energy storage solution for small household, conventional balconies, courtyards, family carports, and other plug & play scenarios. This system has 3 main functions:

1. Utilizes abundant sunlight during daytime to generate electricity to charge DCU1000;
2. Conversion of stored energy at night for home appliances;
3. Can be used as a backup energy source in case of emergency.

P1000+DCU1000 is a portable storage power station. P1000 has AC output interfaces and USB interfaces. It can connect PV modules and charge DCU1000. This solution, P1000+DCU1000, is typically used for outdoor scenarios .

DCU1000

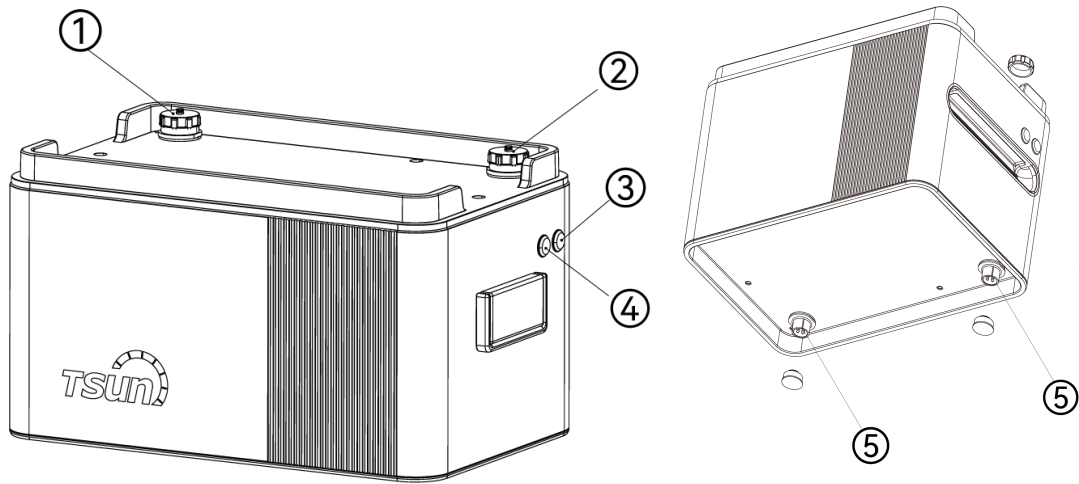

- ①:PV Input
- ②:DC Output
- ③:WIFI
- ④:Power Button
- ⑤:Battery Port

P1000

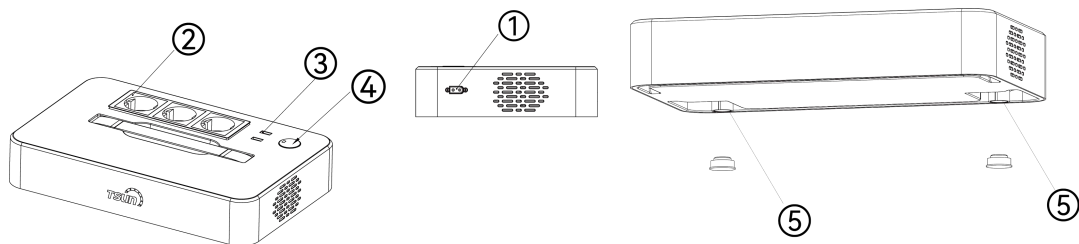

- ①:PV Input
- ②:AC Output
- ③:USB Port
- ④:Power Button
- ⑤:Battery Port

How to install DCU

Pre-installation

- This user guide only describes the cable connection method and assembly of DCU1000/P1000. To install the PV modules, please read the instructions for the PV module and accessories.

- If you want to check the function of the PV system, carry out the installation on a sunny day.
- Make sure DCU1000 is within the WiFi coverage area.
- Please check the accessories before installation, some accessories need to be purchased separately.
- Please do not expose the device to direct sunlight, rain, or snow, and ensure that it is kept in well-ventilated conditions.

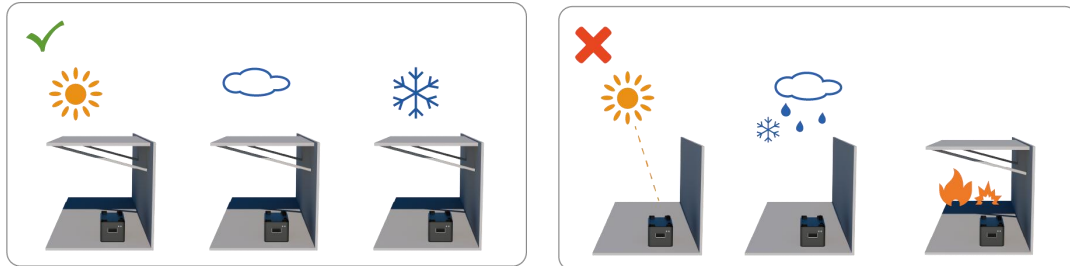

- Before installing or disassembling the DC1000 and P1000, make sure the device is turned off and disconnected to PV modules and microinverter.

INDOOR:Balcony Storage System



Only one DCU1000

1. Remove input and output port protective caps.

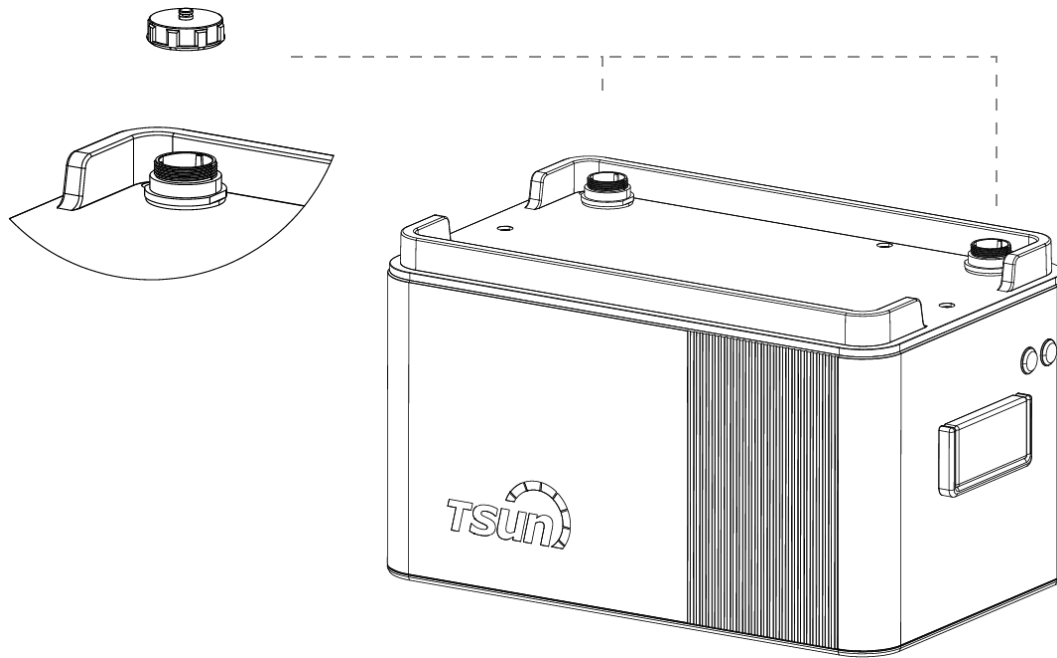

Note:

- Please keep the removed protective cap properly for future use.
- Unscrew the covers of the two connectors on the DCU1000 counterclockwise.

2. Connect DCU1000 with microinverter.

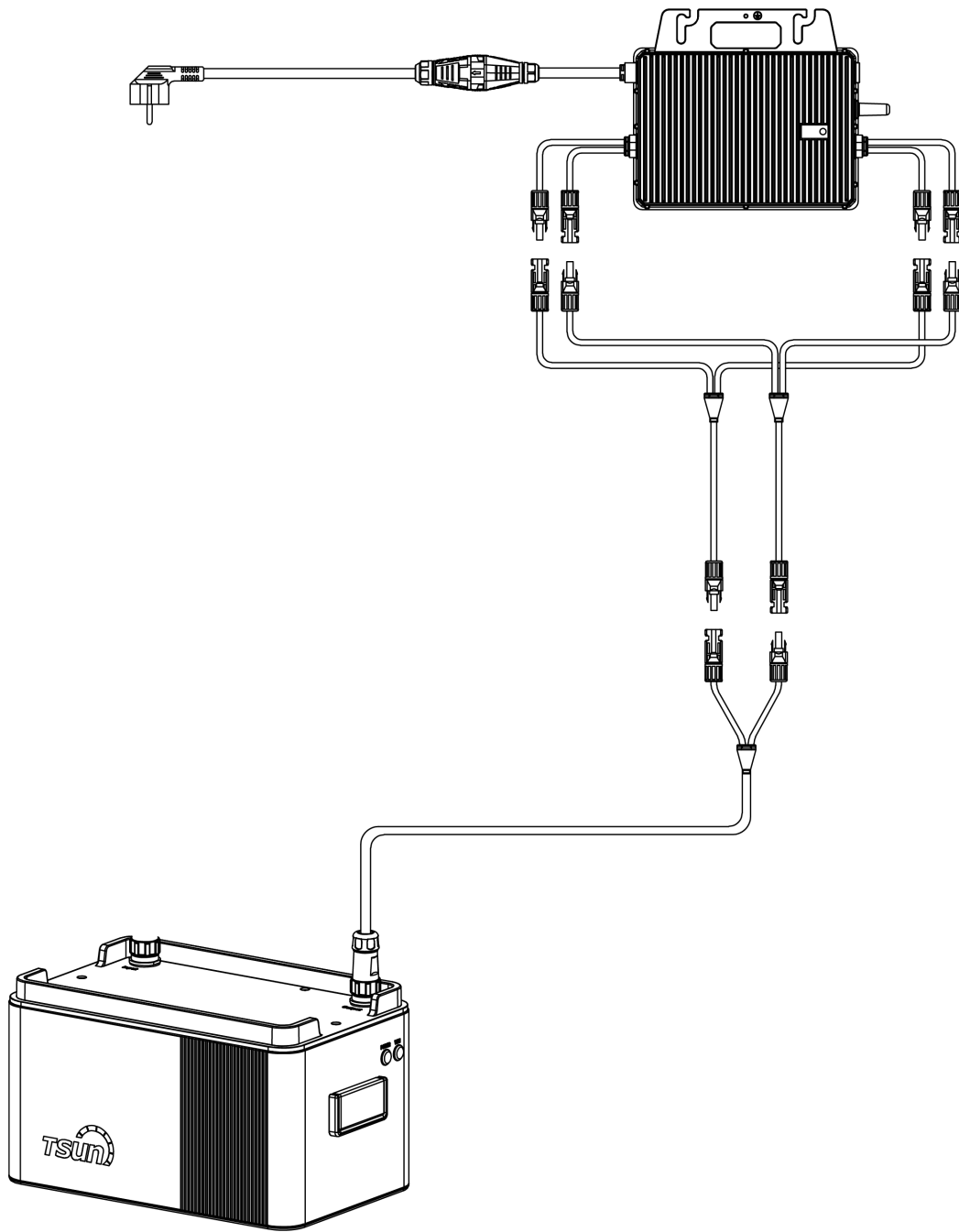

3. Connect two PV panels to the PV input port of DCU1000 .

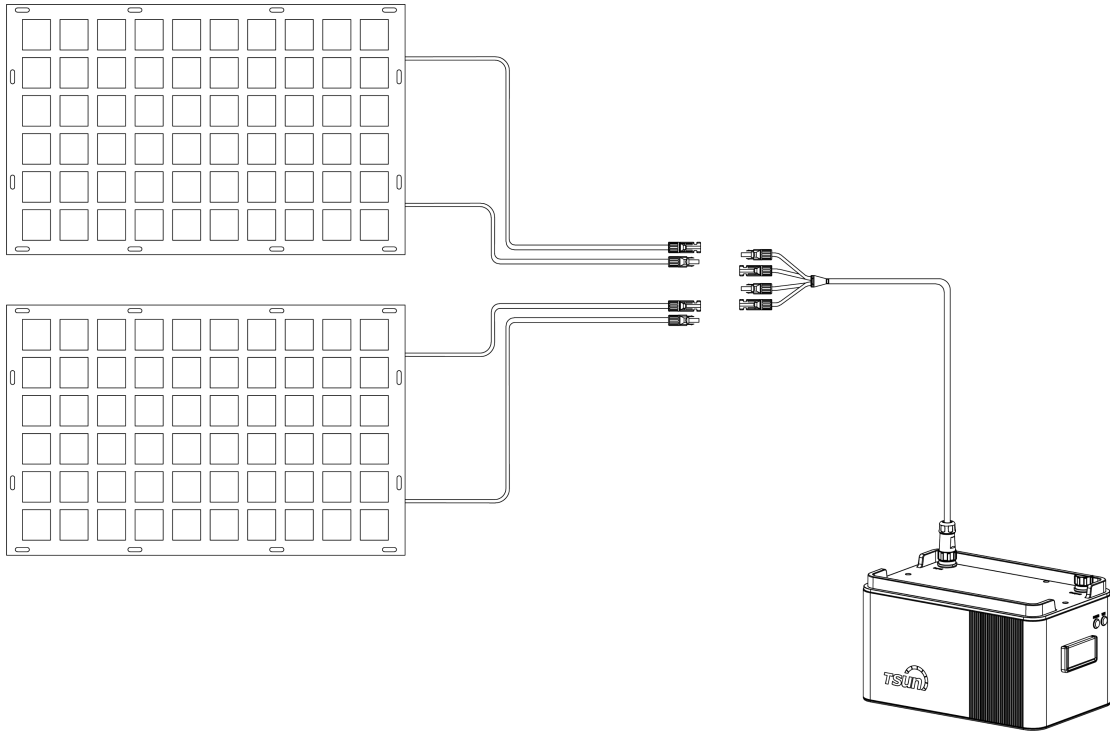

	<p>Warning:</p> <p>Each panel must not exceed 600W.</p>
--	--

The final system diagram should be like below:

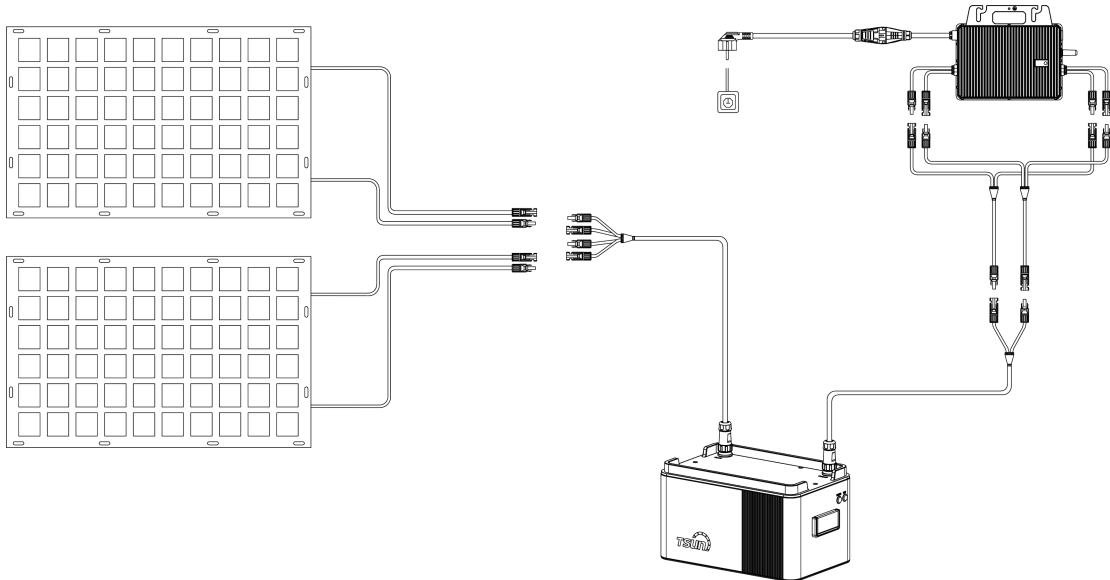

4. Power on/off DCU1000

	<p>Note:</p> <p>Please power on the device after finishing installing the whole system (PV module, DCU 1000, microinverter and grid)</p>
---	---

- Power on

It will be automatically powered on when connecting to PV input.

If no PV input, please press and hold the Power button for 2s still the Power indicator is light up for start-up (if multi-modules are connected in parallel, please start them up in turn).

- Power off :

Please press and hold the Power button for about 5s till the indicator light is OFF for shutdown (if multi-modules are connected in parallel, please shut them down in turn).

Working Status	LED Status
Self-Test	blinking approx.10s
In Operation	1)With charging , no discharging: 3s on, 1s off; 2)With discharging, no charging: 1s on, 3s off; 3)With charging and discharging: 1s on, 1s off.

More than one DCU1000+DCU1000

1. Remove DCU1000 battery connecting port protective cap.

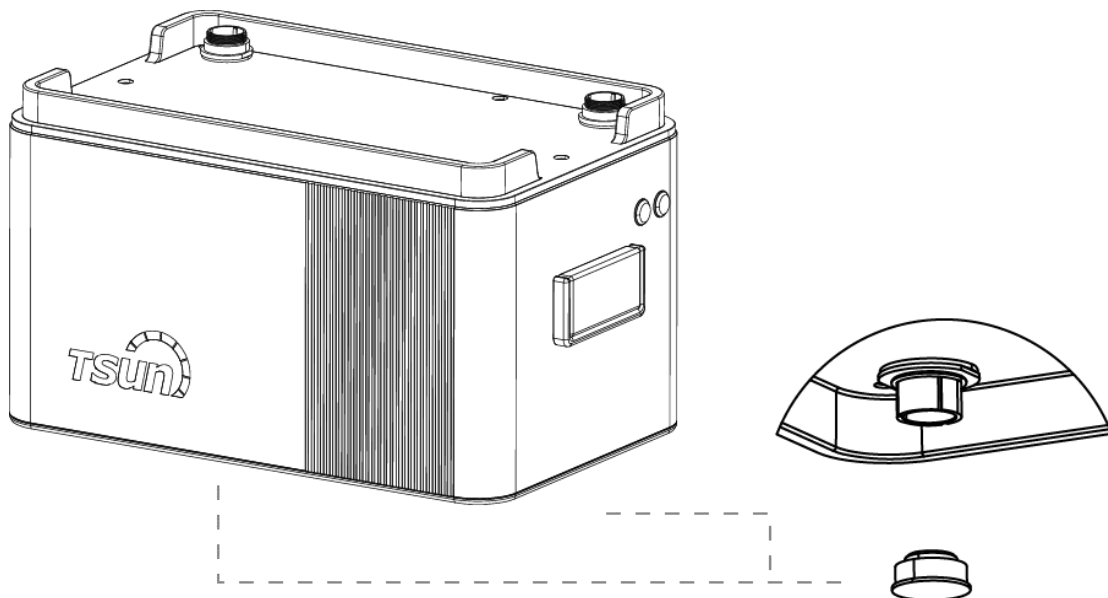

2. Remove input and output port protective cap.

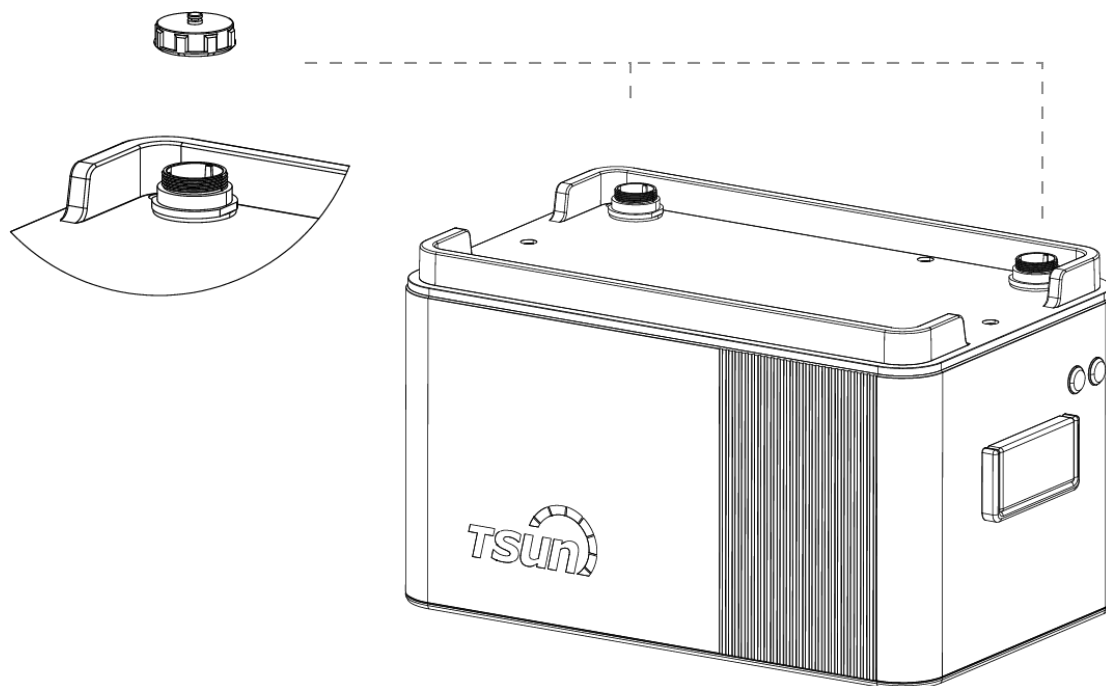

Note:

Please keep the removed protective cap properly for future use.

3. Stack DCU1000 on DCU1000 .

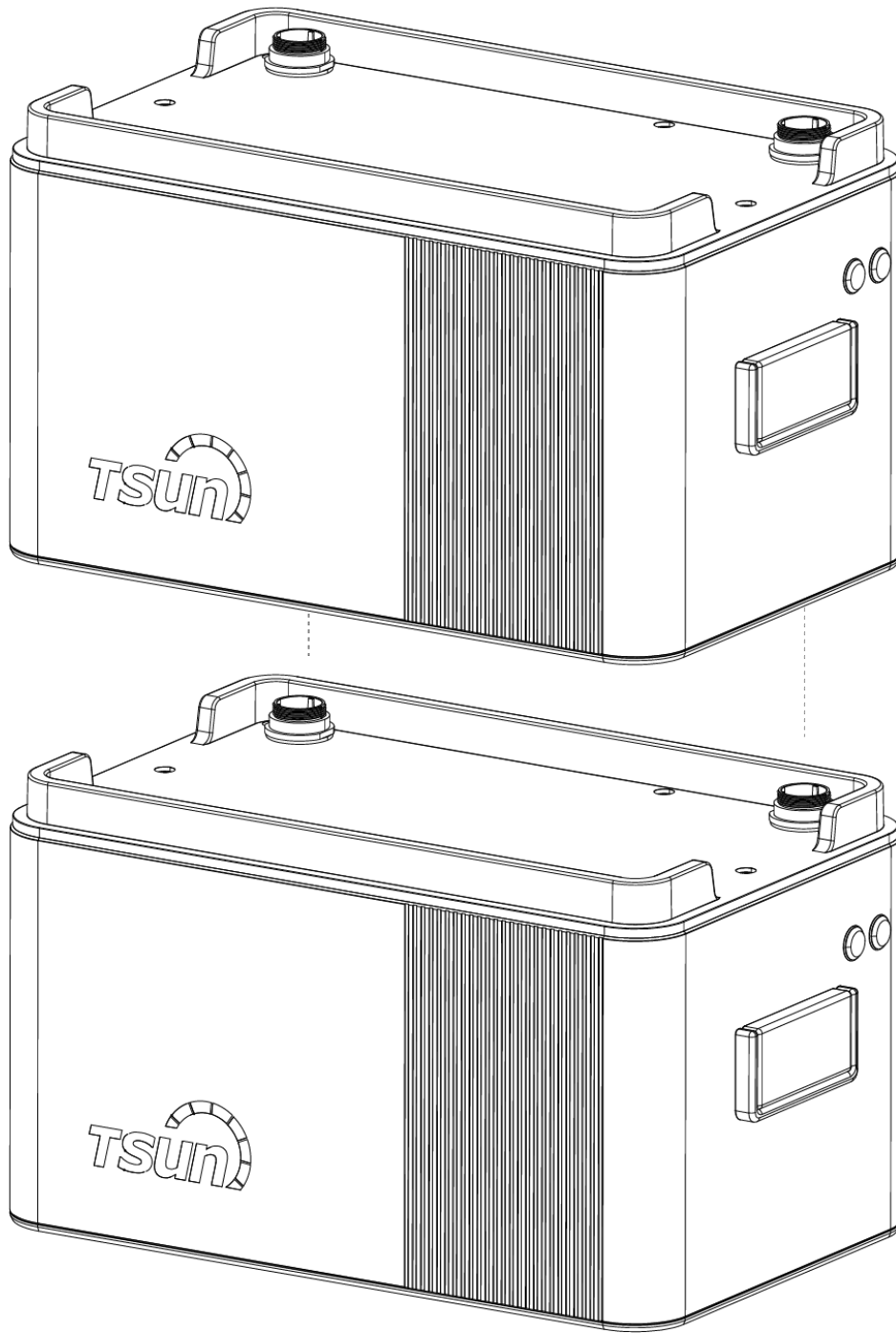

4. Connect DCU1000 with microinverter.

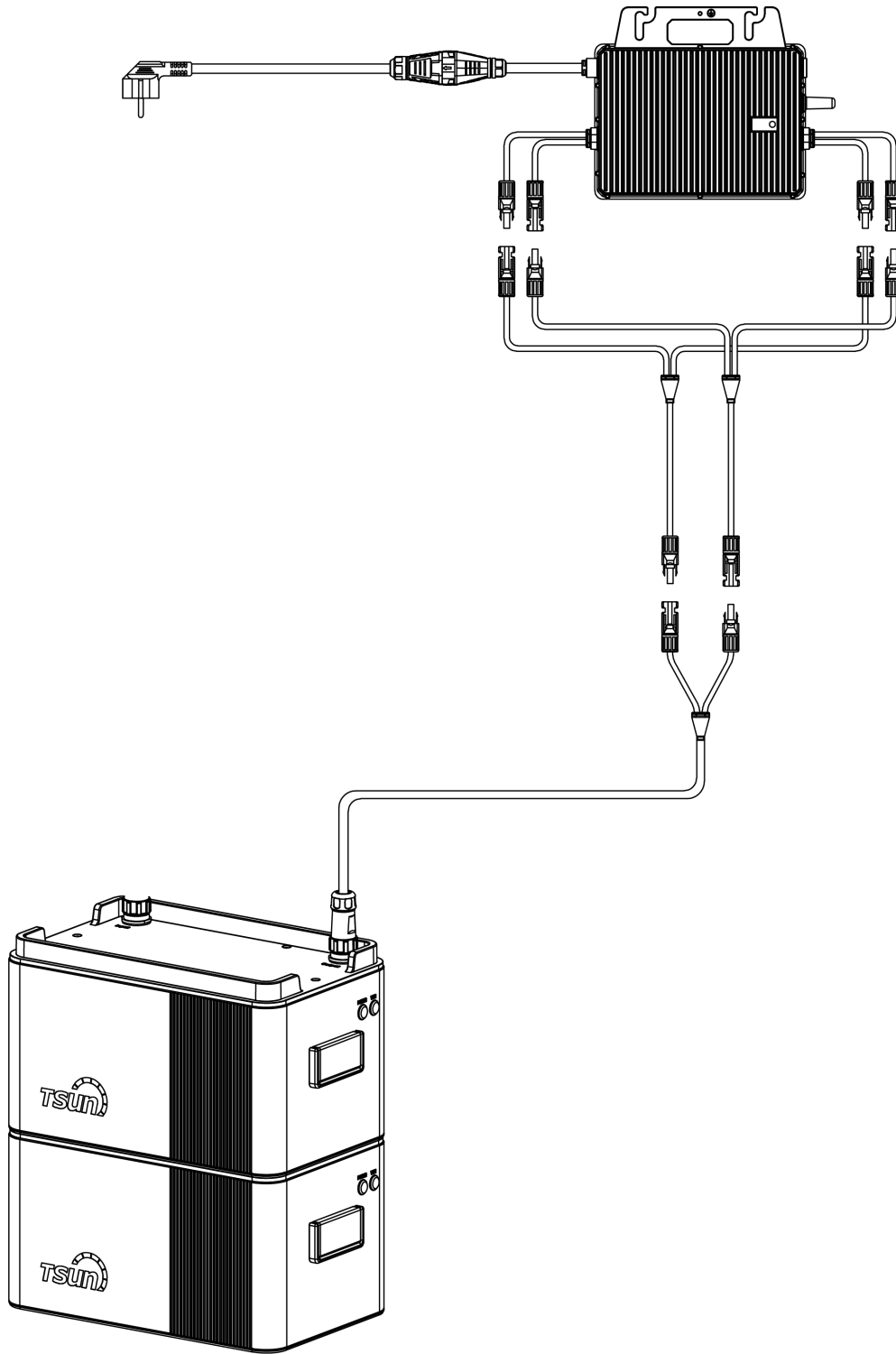

5. Connect PV panels

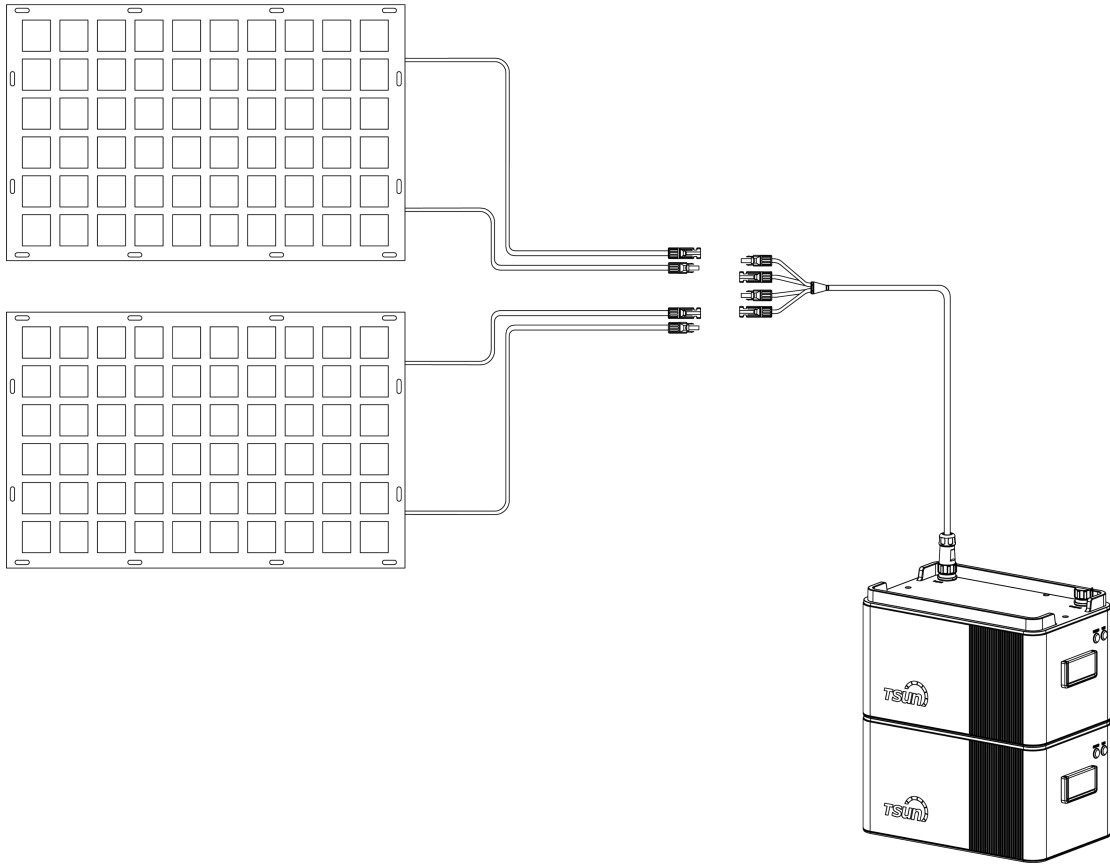

Warning:

Each panel must not exceed 600W.

The final system diagram should be like below:

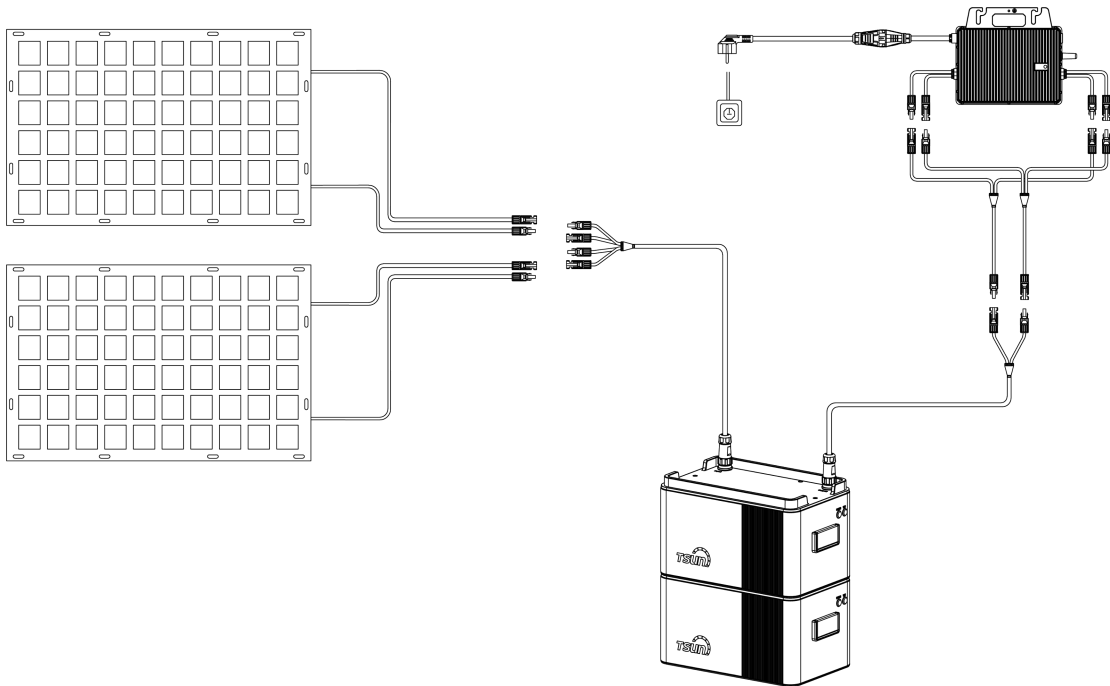

6. Power on/off DCU1000

**Note:**

Please power on the device after finishing installing the whole system (PV module,DCU 1000,microinverter and grid).

- Power on:

It will be automatically powered on when connecting to PV input.

If no PV input, please press and hold the Power button for 2s still the Power indicator is light up for start-up (if multi-modules are connected in parallel, please start them up in turn).

- Power off :

Please press and hold the Power button for about 5s till the indicator light is OFF for shutdown (if multi-modules are connected in parallel, please shut them down in turn).

Working Status	LED Status
Self-Test	blinking approx.10s
In Operation	1)With charging , no discharging: 3s on, 1s off; 2)With discharging, no charging: 1s on, 3s off; 3)With charging and discharging: 1s on, 1s off.

Monitoring System

Preparation

1. IOS users can directly search for "TSUN Smart" in the APP Store and download the software.
2. Android users can directly search for "TSUN Smart" in Google Play and download the software.
3. Android users who cannot access Google Play can scan the QR code below to download and install "TSUN Smart".



Register&Log in

Click "Register", select "End User", and fill in all registration details & read the T&C and Privacy Policy.

The first screenshot shows the login screen with the TSUN logo and the slogan 'MORE SAFETY MORE POWER'. It features input fields for 'E-mail' (demo@tsun-ess.com) and 'Username', a password field, and a 'Log In' button. There are also links for 'Register' and 'Forgot your password?'. The second screenshot shows the 'Register' screen with two options: 'I am a Distributor or Installer' and 'I am an End User'. The third screenshot shows the registration form for 'I am an End User' with fields for 'Country/Region' (China), 'E-mail', 'Verification Code', 'Username', and 'Password'. It includes a 'Send' button for the verification code and a 'Register' button at the bottom.

Add Plant

Click "+" to create a solar plant. After filling in the plant information, click "Save" to complete the solar plant creation.

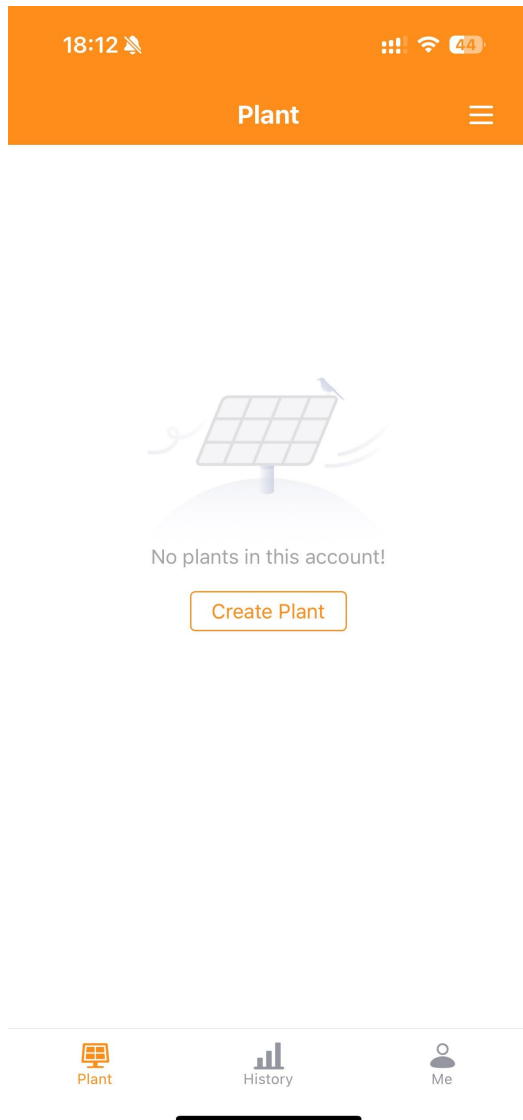

Add Device

- Click “☰” on the plant homepage and click "Device List" on plant homepage.
- Click "Add Device", add "DC Coupled Unit"
- Scan QR code on DCU1000. The QR code label is on the back of DCU1000.

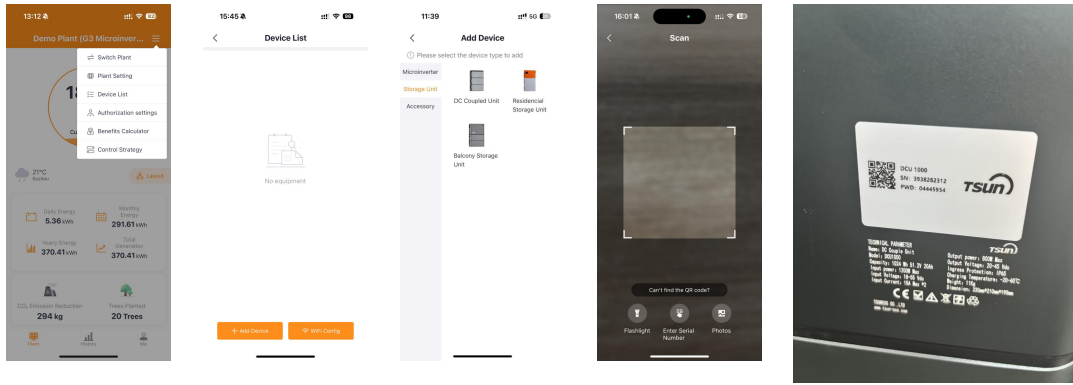

When you stack multiple DCU1000 , only one DCU1000 WIFI LED light will be on.
Please scan the SN and add this device.

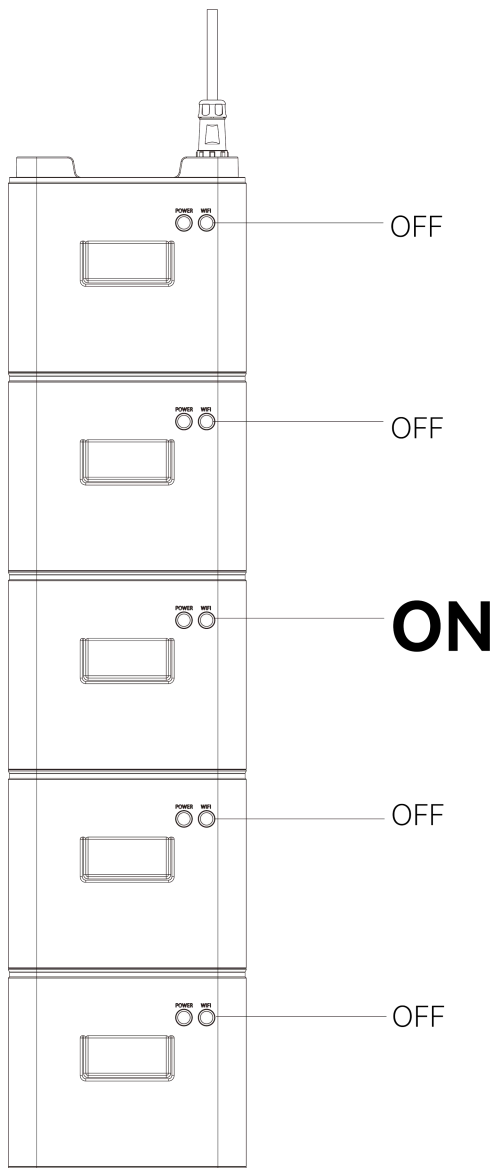

WiFi Configuration

- Click “☰” on the plant homepage and click "Device List" on plant homepage.

- Click "WiFi Config" to select the corresponding DCU1000 for network configuration.
- Click "Start Config" to start configuration .
- Select the WIFI you want to connect to, input the WIFI password, and click "Start Config" again.

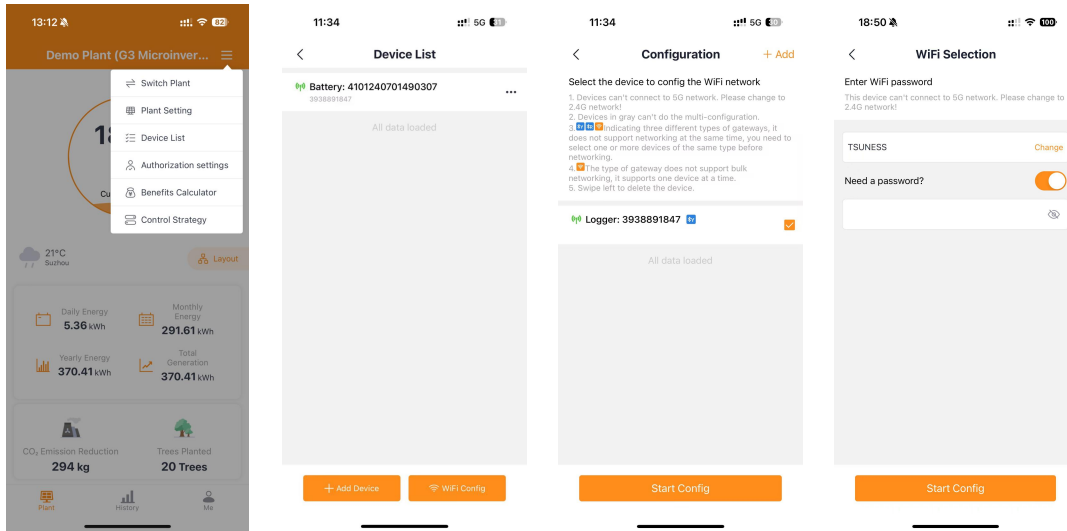

During the network configuration process, please use the 2.4GHz network. If the page displays an error, check the following possible causes and try again:

- Check if the WIFI password is correct or not , and make sure WIFI names no special characters, only numbers and English letters are acceptable .
- Check if WiFi and router work only in 2.4Ghz , the device cannot connect to the 5G network.
- WiFi signal strength should be at least 2 bars shown on the phone.
- One router can only connect to up to 9 devices (not only DCU1000,microinverter, but also phones, PCs, etc.).
- Make sure that the phone's WLAN is turned on
- Try shortening the distance between the phone and the device

After approximately 10 seconds, the WiFi configuration will be completed successfully, and the data of DCU1000 will be uploaded to the server soon.

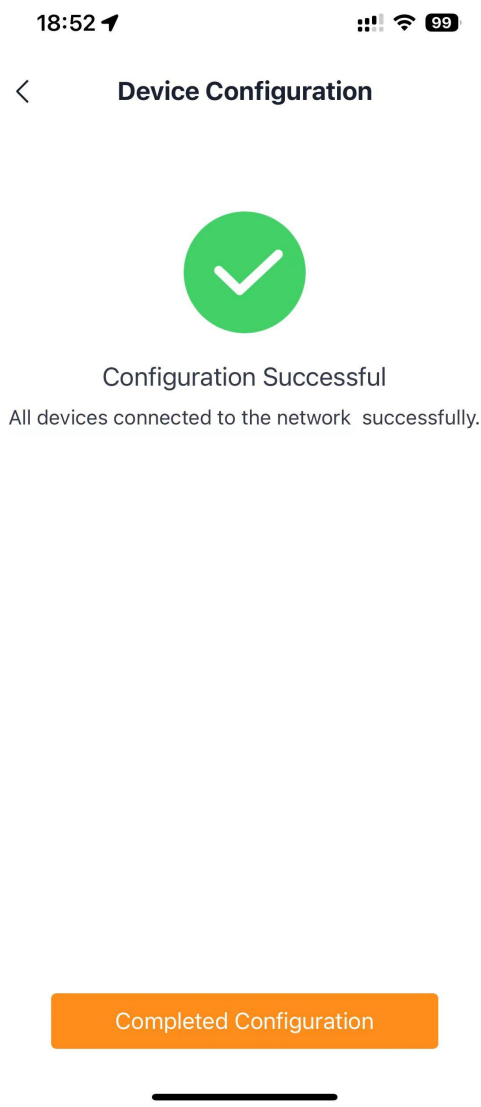
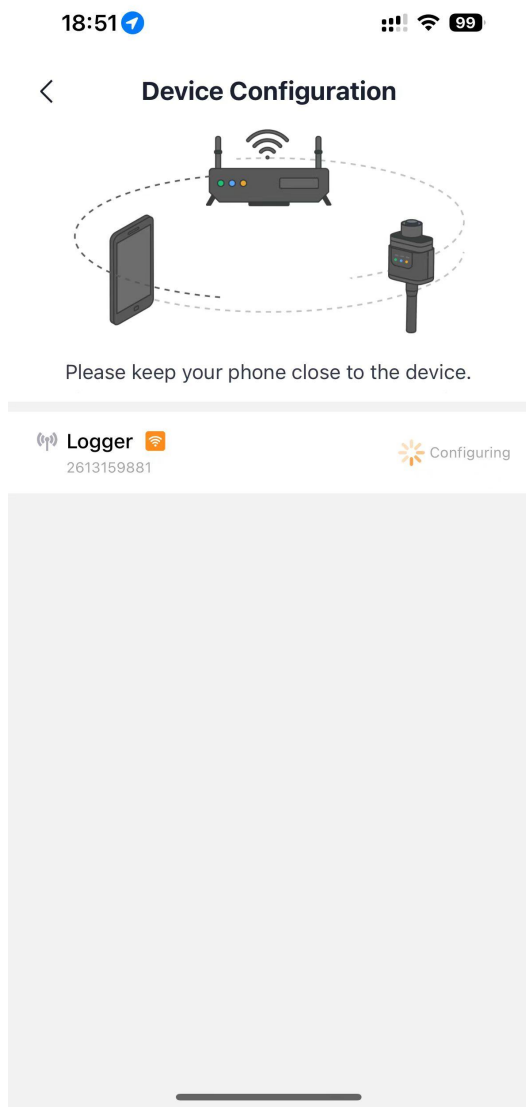

Modify Output Power

The default output power of DCU1000 is 150W. If you want to modify output power, click "Device List" on plant homepage, and click "Remote Control" on Device List interface, input the outpower which you need (output power must be 100W-800W), then click "Setup" to finish setting.

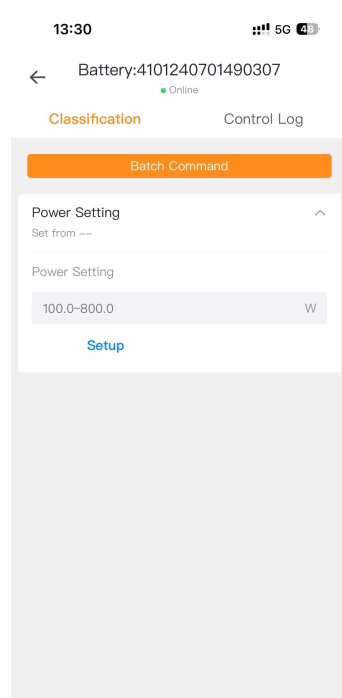
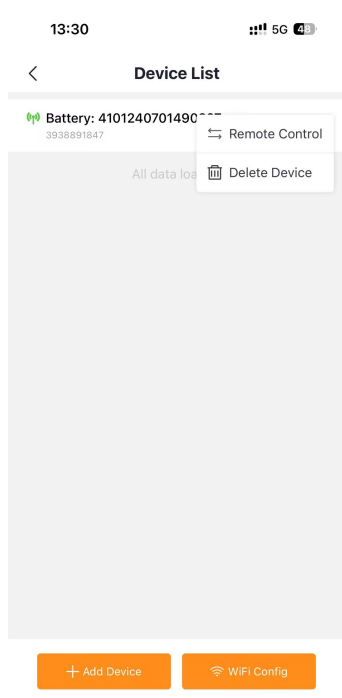
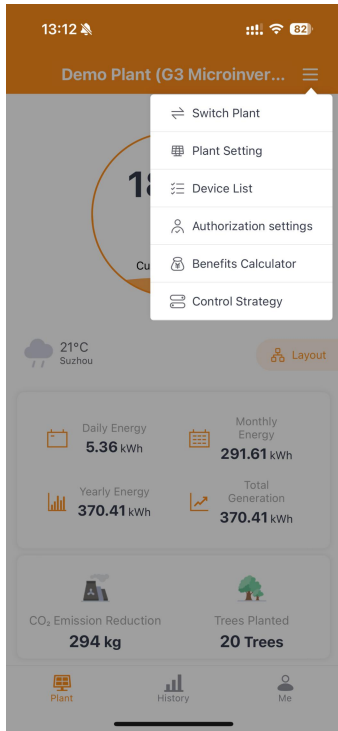

Time-of-Day Setting

- Click “☰” on the plant homepage and click "Control Strategy" on plant homepage.
- Click "Go to Configuration" to enter the configuration details page.
- Turn on the Time-of-Day Strategy Switch.
- Click "Modify Rules" to set the power output for different time periods. (Support up to 3 time periods).

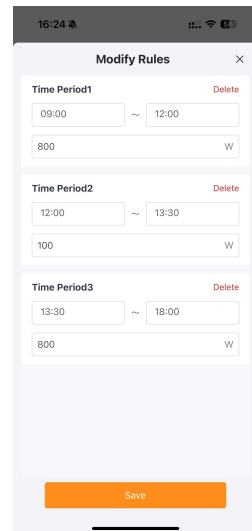
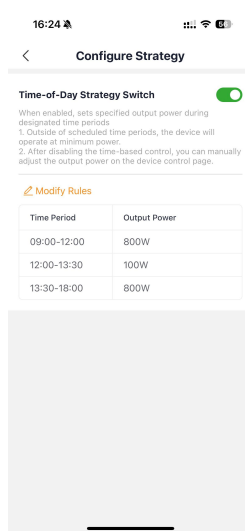
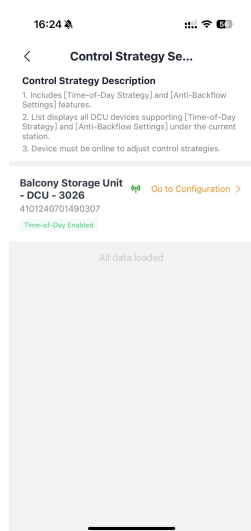
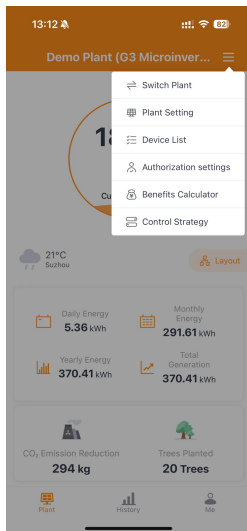

Zero Export Setting

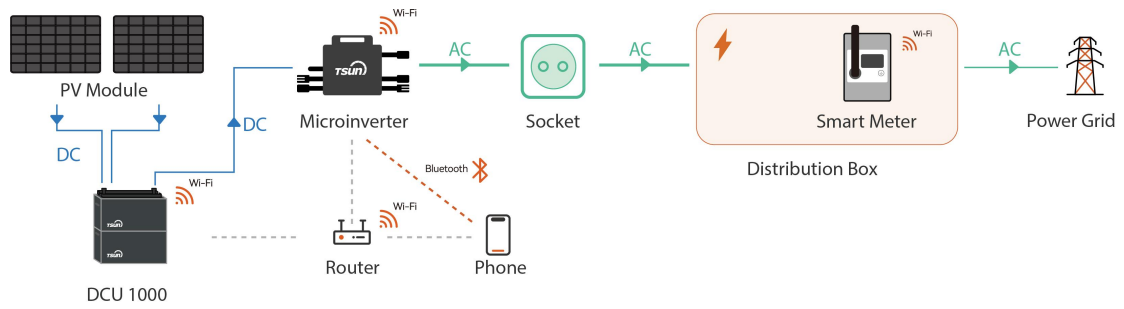

If you want the system to have zero export function, you need to configure the WiFi smart meter. For detailed instructions on how to configure the smart meter, please refer to the smart meter user manual.

Note:

Smart meter need to be purchased separately .

To activate the anti-reverse flow function, click “☰” on the plant homepage and click “Control Strategy”, then click “Go to Configuration”. Turn on the Anti-Reverse Flow Configuration.

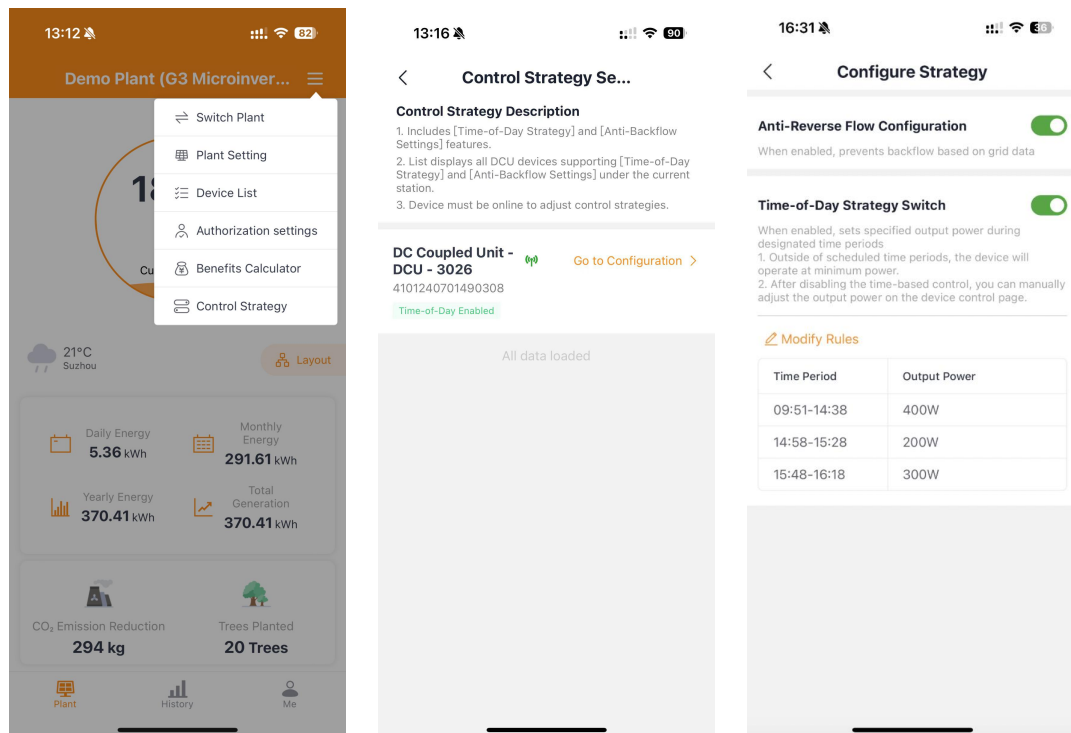

OUTDOOR: Portable Storage Power Station



1. Remove DCU1000 and P1000 battery port protective caps.

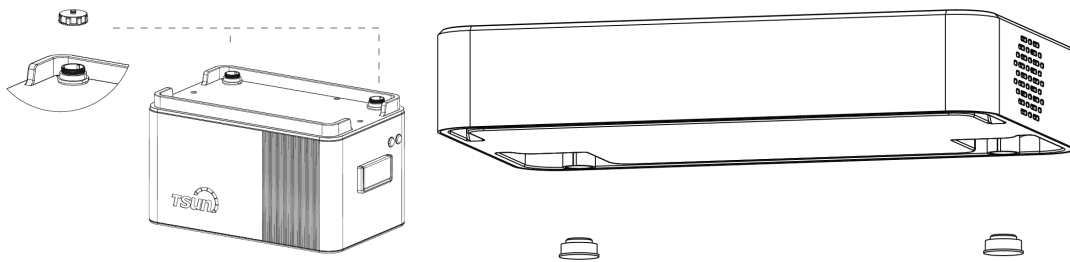

2. Stack P1000 on DCU1000 .

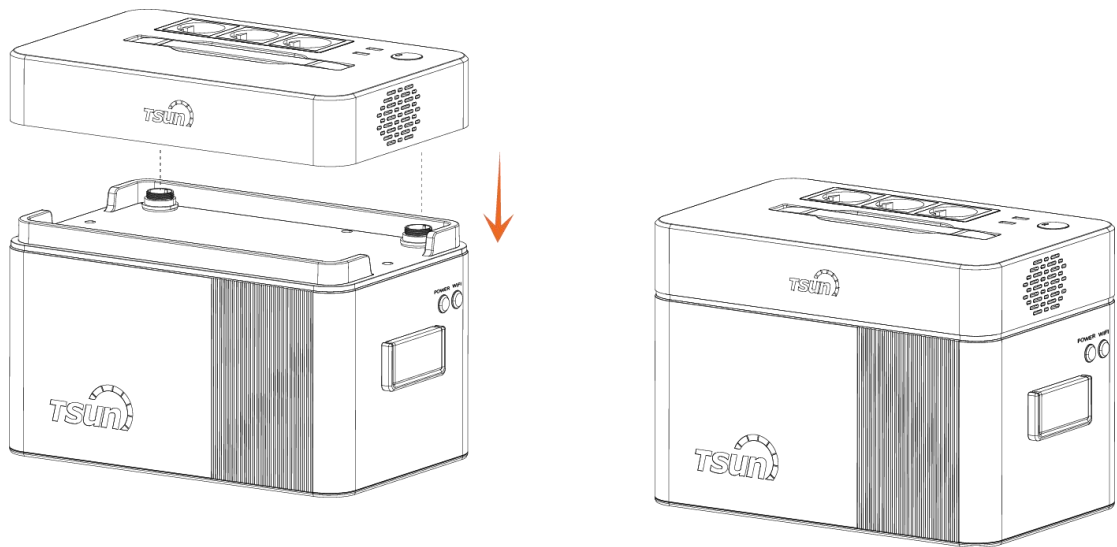

3. Power on P1000 and DCU1000.

- DCU1000:

Press and hold the Power button for about 2s ,and then release to power on DCU1000.

- P1000

Press the button to turn on P1000.

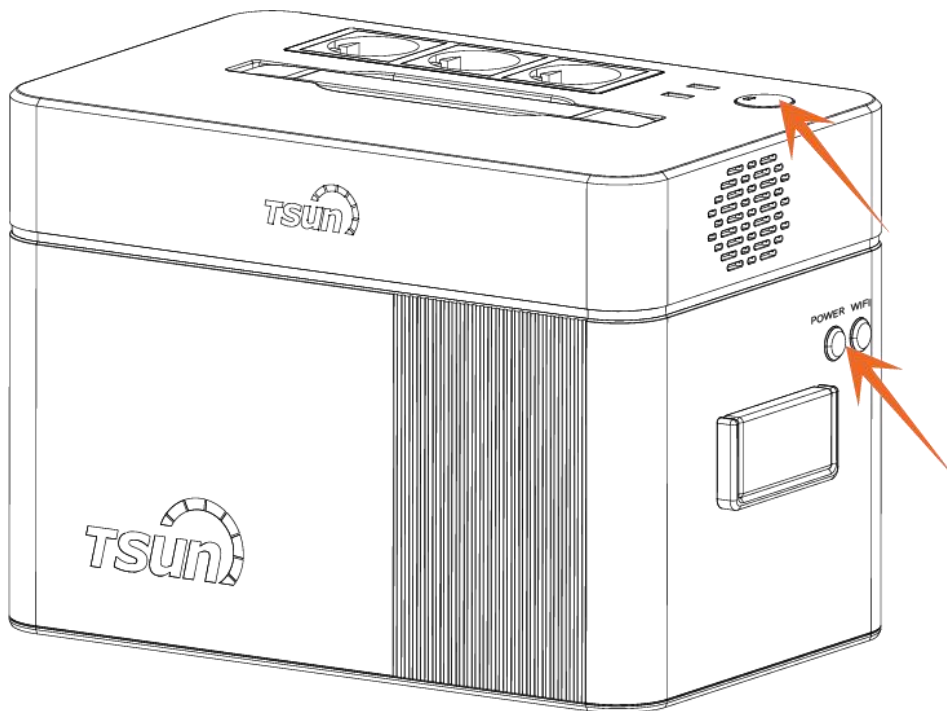

4. Connect loads.

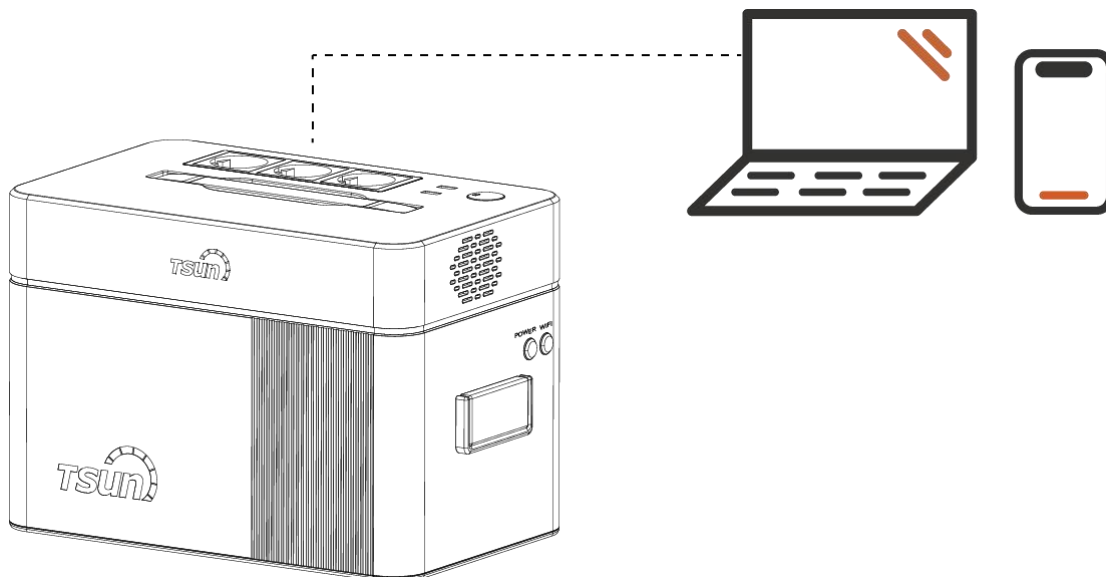

Note:

The USB port on P1000 might not be compatible with the USB charging cable of some models of iPhone, in this case, please kindly use iPhone adaptor and plug it into the socket of P1000.

5. Connect the PV panel to the input port of P1000 (Optional).

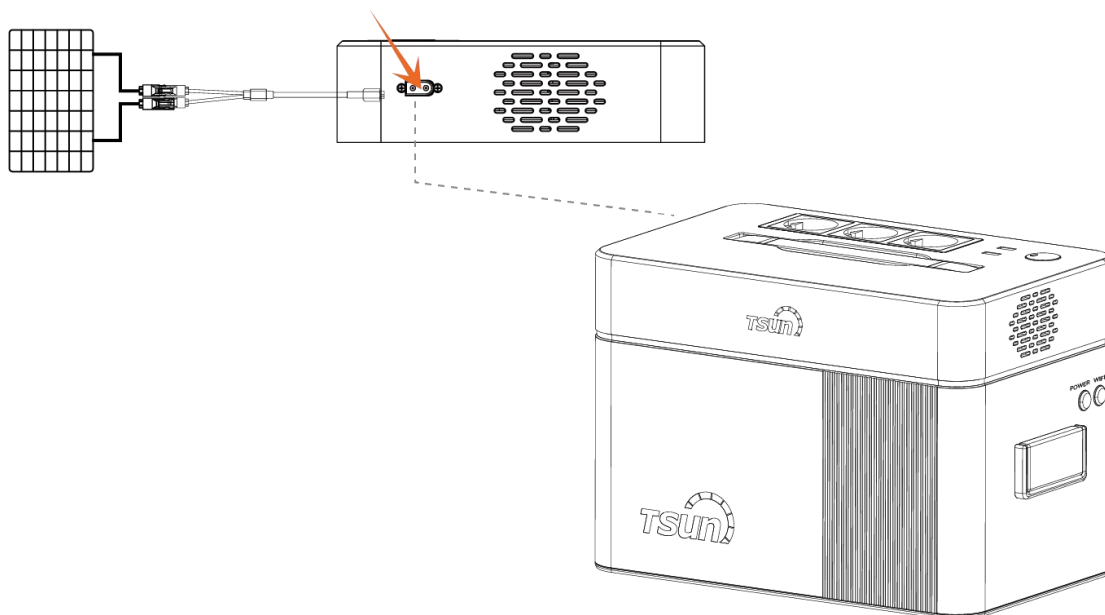

Warning:

Max. input power of P1000 is 600W.

6. Power off P1000 and DCU1000. Once all indicator lights are OFF, disassemble P1000 and DCU1000.

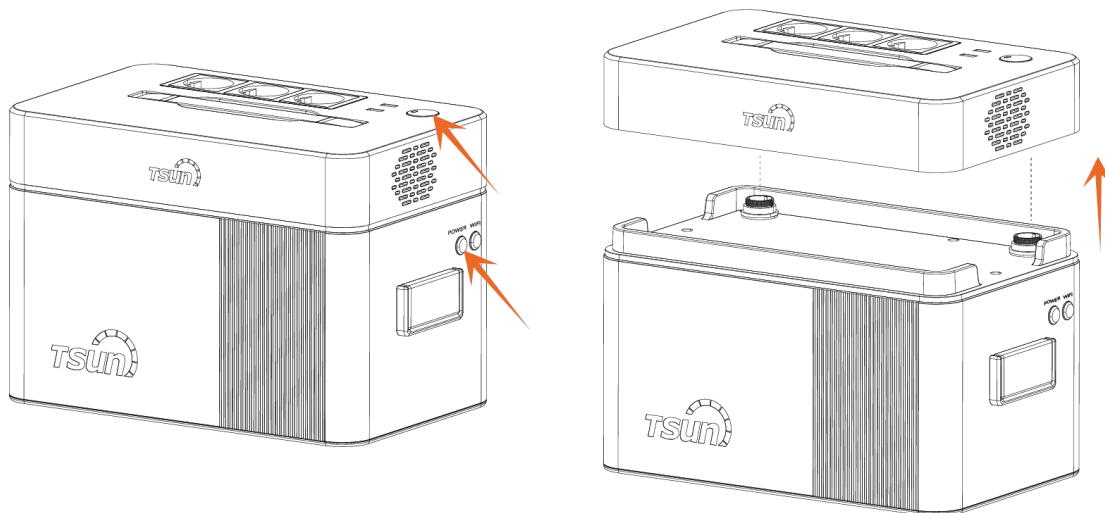

- DCU1000:

Please press and hold the Power button for about 5s till the indicator light is OFF for shutdown (if multi-modules are connected in parallel, please shut them down in turn).

- P1000:

Press the button to turn off P1000.



Note:

Portable Storage Power Station do not support data monitoring and TSUN smart app.

FAQ

1. How many PV panels can be connected to each DCU1000?

Each DCU1000 can be connected to two Max. 600W PV panels. When multiple DCU1000 are connected in parallel, DCU1000 (the topmost battery pack) is connected to the PV panels.

2. How to clean DCU1000 ?

Since it is placed outside on the balcony and exposed to wind and sun, we recommend a simple cleaning routine. Please use a dry, non-abrasive cloth for wiping. If a deeper clean is desired, consider using a professional screen cleaner for phones or computers. However, be careful not to allow a large amount of liquid to enter the device or terminals, as this could damage the internal circuits or affect terminal conductivity, which could pose a risk to personal safety.

3. How to use this device safely and what precautions should be taken?

When using DCU1000/P1000, pay attention to the temperature range of the working environment . This product will perform optimally within its suitable temperature range. Working the machine outside of this temperature range may significantly reduce its performance and could potentially shorten its lifespan.

4. How is the safety performance of this device?

DCU1000/P1000 has sufficient safety performance and certifications, making it suitable for indoor and outdoor use.

5. In what range of environmental temperatures is this device suitable for use?

It is recommended to use the device within the range of -20°C to 45°C. Working outside of this range may affect the efficiency of charging and discharging. When temperature is below 0°C, only discharging is possible, charging is not recommended.

Product Maintenance

Storage

1. Please store the product in a place far from water sources and heat sources.
2. To extend the battery lifespan, it is best to use or store this product in an environment with a temperature range of 20°C to 30°C. For safety reasons, do not store this product in an environment with temperatures above 45°C or below -20°C for a long time.
3. For long-term storage, please charge and discharge this product once every 3 months. Products that have not undergone charging and discharging for more than 3 months will not be covered by the warranty.
4. If the battery level of this product is critically low and it has been idle for an extended period, it needs to be recharged before it can be used again.

Recycling and Disposal

The battery cannot be disposed of as household refuse. When the service life of the battery reaches to the limit, it is not required to return it to the dealer or TSUNESS, but it must be recycled to the special waste lithium battery recycling station in the area.

Warranty

1. Product warranty period of 5 years. In all cases, the warranty period starts from the date of purchase by the consumer. In order to ensure the start date of the warranty period, the consumer needs to provide proof of purchase or other reasonable supporting documents.
2. This warranty is subject to the following conditions:
 - The product must have been installed and correctly commissioned by an authorized and licensed installer. Proof may be required of correct commissioning of the product (such a certificate of compliance). Claims for failures due to incorrect installation or commissioning are not covered under this

warranty.

- Where a product or part thereof is replaced or repaired under this warranty, the remaining balance of the original warranty period will apply. The replacement product or part(s) do not carry a new voluntary warranty.
- The product must have its original serial number and rating labels intact and readable.
- This warranty does not extend to any product that has been completely or partially disassembled or modified, except where such disassembly is carried out by TSUNESS.
- The terms of this warranty cannot be amended except in writing by one of our authorized officers.
- There must have been a commissioning report signed by the end user and the installer for product commissioning and handling instructions.

Exclusions

1. TSUNESS makes no warranties, either expressed or implied, orally, or in writing, concerning any other warranty coverage except those expressly stated in this limited Factory warranty.
2. The Factory warranty does not cover damages that occur due to:
 - Transport damage;
 - Installation or commissioning through any person who is not an Authorized, Certified Dealer;
 - Failure to observe the user manual, maintenance regulations, and intervals;
 - Modifications, changes, or attempted repairs, except as conducted by an Authorized Dealer;
 - Incorrect use or inappropriate operation;
 - Insufficient ventilation of the covered product;
 - Failure to observe the applicable safety regulations;
 - Force majeure.
3. This factory warranty does not cover cosmetic defects which do not directly influence energy production, or degrade form, fit, and function.
4. Claims that go beyond the scope of this limited factory warranty, in particular claims for compensation for direct or indirect damages arising from the defective device, for compensation for costs arising from disassembly and installation, or loss of profits, are expressly NOT covered by this factory warranty.
5. In no event will TSUNESS Co., Ltd be held responsible or liable for any personal injuries resulting from the use of the system, or for any other damages, whether direct, indirect, incidental, or consequential; even if TSUNESS Co., Ltd has

been advised of such damages.

Appendix

Product Certificates

TSUNESS Co., Ltd declares that the radio equipment (DC Coupled Unit) is in compliance with Directive

2014/53/EU. The full text of the EU Declaration of Conformity is available at the following internet

address:https://www.tsun-ess.com/files/10_1729490951838.pdf

OPERATING FREQUENCY (the maximum transmitted power)

2412MHz—2472MHz(EIRP < 20dBm)

2402MHz—2480MHz(EIRP < 10dBm)

DCU1000 Datasheet

Project Description	Technical Specifications	Remark
Capacity	1024 Wh	
Dimensions (L*W*H)	330*210*195(mm)	Single Module
Weight	24.25lbs/11Kg	
Battery Type	LiFePO4	
Cycle Times	6000 cycles, remaining capacity ≥ 70%	
Max. Input Power	1200W	600W*2
Maximum Output Power	800W	According to EU standards
PV input voltage range	18~55V	
Max. input current	15A*2	
Range of output	20~45V	

voltage		
Maximum Number of Parallel Battery Packs	5	
Maximum scalable capacity	5120Wh	
Waterproof rating	IP65	
Charging/Discharging ambient temperature	-20~45℃	Charging can begin when the battery cell temperature is heated to 0℃
Protection	Overcharge, over-discharge, overcurrent, high-temperature, low-temperature and short-circuit protection, PV high voltage rapid shutdown function	
Wireless communication	Bluetooth, Wi-Fi	
Communication	CAN	
Operating temperature	-20℃~45℃	Activate electric heating when the battery cell temperature is < 5℃. Charging can begin when the battery cell temperature is heated >0℃
Storage temperature	-20℃~45℃	
RH	5~95%	No condensation
Altitude	≤4000 m	
Barometric Pressure	70K~106KPa	

P1000 Datasheet

Project Description	Technical Specifications	Remark
Dimensions (L*W*H)	330mm*210mm*235(mm)	
Weight	5.51lbs/2.5kg	
PV Input Voltage	42-58V	Rated Voltage 48V
AC Output Voltage	220V~240V	
Frequency	50Hz/60Hz	
Maximum Input Power	200W	
Maximum Output Power	1000W	
Protection Functions	Input undervoltage, output shortcircuit, output overload,high/low temperature protection, etc.	
Interface	AC Interface, USB-A	