



User Manual

TSOL-MX400 Balcony

TSOL-MX450 Balcony

TSOL-MX500 Balcony

Trademarks and Permissions

TSUN and other TSUNESS trademarks are trademarks of TSUNESS Co., Ltd. All other trademarks and trade names mentioned in this document are the property of their respective holders.

TSUNESS Co., Ltd makes no representations express or implied, concerning this documentation or any of the equipment and / or software it may describe, including (with no limitation) any implied warranties of utility, merchantability, or fitness for any particular purpose.

All such warranties are expressly disclaimed. Neither TSUNESS nor its distributors or dealers shall be liable for any indirect, incidental, or consequential damages under any circumstances. (The exclusion of implied warranties may not apply in all cases under some statutes, and thus the above exclusion may not apply.)

Specifications are subject to change without notice. Every attempt has been made to make this document complete, accurate, and up-to-date. Readers are cautioned, however, that TSUNESS reserves the right to make changes without notice and shall not be responsible for any damages, including indirect, incidental, or consequential damages, caused by reliance on the material presented, including, but not limited to, omissions, typographical errors, arithmetical errors or listing errors in the content material.

All trademarks are recognized even if these are not marked separately. Missing designations do not mean that a product or brand is not a registered trademark. All trademarks are recognized as the property of their respective owners.

Product information is subject to change without notice. User documentation is updated frequently; Check www.tsun-ess.com for the latest information. To ensure optimal reliability and meet warranty requirements, the TSUN Microinverter must be installed according to the instructions in this manual. For warranty text refer to www.tsun-ess.com.

© 2022 TSUNESS Co., Ltd All rights reserved.

Audience

This manual is intended for use by professional installation and maintenance personnel.

Content

Trademarks and Permissions	- 1 -
Audience	- 2 -
Content	- 3 -
Read This First	- 4 -
Important Safety Information	- 4 -
Product Label	- 4 -
System Introduction	- 5 -
Product Description	- 6 -
Datasheet	- 7 -
Microinverter Installation	- 8 -
Pre-installation Check	- 8 -
Installation Steps	- 9 -
Remote Active Power Control	- 14 -
Self-Test Function for Italy	- 14 -
Fault Code and Troubleshooting	- 15 -
Maintenance Guide	- 16 -
Routine Maintenance	- 16 -
Storage and Dismantling	- 16 -
Recycling and Disposal	- 17 -
Warranty Service	- 17 -
Exclusions	- 17 -
Distributor Responsibility	- 18 -

Read This First

Dear customer, thank you for choosing the Balcony microinverter from TSUN. We hope you will find our products meet your needs for renewable energy. Meantime, we appreciate your feedback regarding our products.

A solar microinverter, or simply microinverter, is a plug-and-play device used in photovoltaics, that converts direct current (DC) generated by a single solar module to alternating current (AC). The main advantage is that small amounts of shading, debris, or snow lines on any single solar module, or even a complete module failure, do not disproportionately reduce the output of the entire array. Each microinverter harvests optimum power by performing maximum power point tracking (MPPT) for its connected module. Simplicity in system design, lower amperage wires, simplified stock management, and added safety are other factors introduced with the microinverter solution.



This manual contains important instructions for Balcony microinverters and must be read in their entirety before installing or commissioning the equipment. For safety, only qualified technicians, who have received training or have demonstrated skills can install and maintain this microinverter under the guide of this document.

Important Safety Information







During installation, testing, and inspection, adherence to all the handling and safety instructions is mandatory. Failure to do so may result in injury or loss of life and damage to the equipment.

Product Label

The following safety symbols are used in this document. Familiarize yourself with the symbols and their meaning before installing or operating the system.

 DANGER
· DANGER indicates a hazardous situation that can result in deadly electric shock hazards, other serious physical injury, or fire hazards.
 WARNING
· WARNING indicates directions that must be fully understood and followed in their entirety in order to avoid potential safety hazards including equipment damage or personal injury.
 CAUTION
· CAUTION indicates that the described operation must not be carried out. The reader should stop using and fully understand the operations explained before proceeding.

The symbols on the microinverter are listed below and illustrated in detail.

Symbol	Description
	This device is directly connected to the public grid, thus all work to the inverter shall only be carried out by qualified personnel.
	The components inside the inverter will release a lot of heat during operation. Do not touch metal plate housing during operation.
	Please read the installation manual first before installation, operation, and maintenance.
	This device SHALL NOT be disposed of in residential waste.
	This device fulfills the requirements of the Radio Equipment Directive.
RoHS	This device complies with the RoHS Directive.
	There is a risk of electric shock during energy conversion. Before releasing the remaining voltage, do not perform any operations and do not enter within 25 centimeters of the surrounding area.

System Introduction

The Balcony microinverter is used in grid-tied applications, comprised of two key elements:

- Balcony Microinverter.
- TSUN monitoring system.

The microinverter converts the DC electricity generated by solar panels into AC electricity which is in accordance with the requirements of the public grid and sends the AC into the grid, reducing the load pressure of the grid.

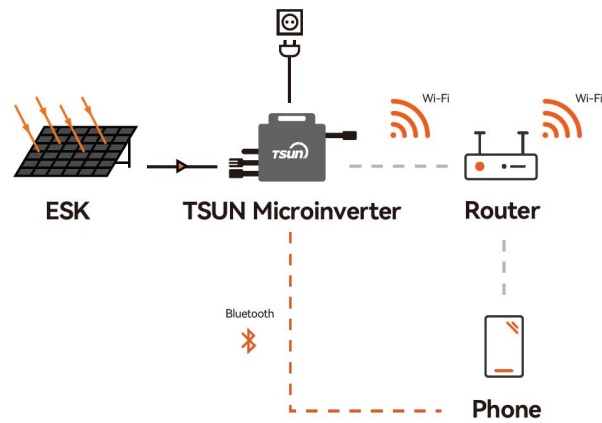

TSOL- MX400 Balcony
 TSOL-MX450 Balcony
 TSOL-MX500 Balcony

The microinverter is integrated with the Wi-Fi module and connects to the home Wi-Fi router directly. Users can monitor the power generation of the system by TSUN monitoring App.

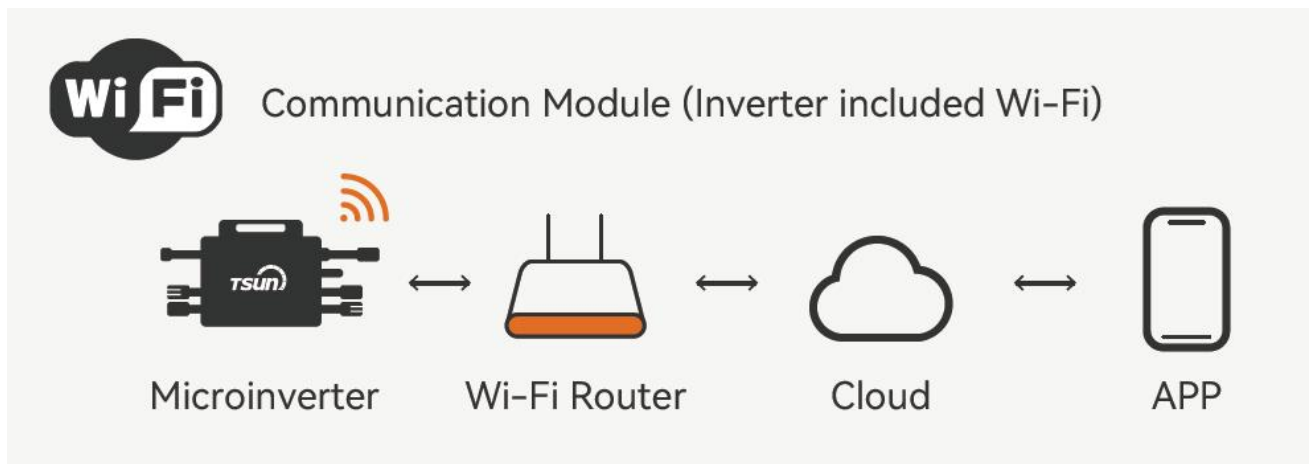

Product Description

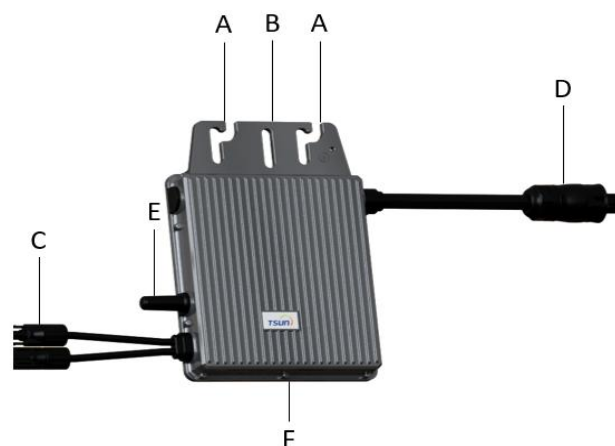

TSOL- MX400 Balcony
 TSOL- MX450 Balcony
 TSOL- MX500 Balcony

A	Mounting Hole	D	AC Cable
B	Grounding Hole	E	Antenna
C	DC Cables	F	Status Light

Datasheet

Model	MX400 Balcony	MX450 Balcony	MX500 Balcony
Input Data (DC)			
Recommended Module Power (Wp)	300 - 550		
Start up Voltage per Input@Rated condition (V)	22		
MPPT Voltage Range per Input (V)	16 - 60		
Nominal DC voltage(V)	42		
Max. Input Voltage per Input (V)	60		
Short-current(A)	20		
Max. Input Current per Input (A)	1 × 14		
Quantity of MPPTs	1		
Number of Inputs per MPPT	1		
Max. inverter backfeed current to the array (A)	0		
Output Data (AC)			
Max. Continuous Output Power (VA)	400	450	500
Nominal Continuous Output Power (W)	400	450	500
Nominal Output Current (A)	1.74	1.96	2.17
Max. Output Current (A)	2.00	2.25	2.50
Nominal Output Voltage (V)	220/230/240, L/N/PE		
Nominal Frequency (Hz)	50/60		
Power Factor	>0.99 default	0.8 leading ... 0.8 lagging	
Output Current Harmonic Distortion	<3%		
Efficiency			
Peak Inverter Efficiency	97.0%		
EU Weighted Efficiency	96.7%		
CEC Weighted Efficiency	96.7%		
Nominal Mppt Efficiency	99.9%		
Mechanical Data			
Dimensions (W×H×D mm)	164 x 225 x 30		
Weight [kg]	1.75		
General Data			
Night Time Power Consumption	<50 mW		

Communication	WiFi module
Type of Enclosure	IP67
Cooling	Natural convection
Type of isolation	Galvanically Isolated HF Transformer
Operating Ambient Temperature Range	-40 ~ +65 °C (derating of over 50°C Ambient Temperature@ PV input 30V)
Relative Humidity	100%
Max. Operating Altitude Without Derating [m]	2000
Over voltage category	III(Mains), II(PV)
Compliance	EN 50549-1: 2019, VDE-AR-N 4105: 2018, VFR2018, IEC/EN 62109-1/-2, CEI 0-21: 2022 / IEC/EN 61000-6-1/-2/-3/-4, IEC/EN 61000-3-2/-3

※ The AC voltage and frequency range may vary depending on specific country grid.

TSUNESS Co., Ltd declares that the radio equipment (Micro inverter) is in complies with Directive 2014/53/EU. The full text of the EU Declaration of Conformity is available at the following internet address:

[https://www.tsun-ess.com/File/\\$random-2023-07-03-091204-@2a\\$-97Z](https://www.tsun-ess.com/File/$random-2023-07-03-091204-@2a$-97Z)

OPERATING FREQUENCY (the maximum transmitted power)

2412MHz—2472MHz(EIRP <20dBm)

2402MHz—2480MHz(EIRP <10dBm)

Microinverter Installation

Pre-installation Check

Check the Package

Although TSUN's microinverters have surpassed stringent testing and are checked before they leave the factory, it is uncertain that the microinverters may suffer damage during transportation. Please check the package for any obvious signs of damage, and if such evidence is present, do not open the package and contact your dealer as soon as possible.

Check the Installation Environment and Position

When choosing the position of installation, comply with the following conditions:

- ◆ To avoid unwanted power derating due to an increase in the internal temperature of the inverter, do not expose it to direct sunlight.
- ◆ To avoid overheating, always make sure the flow of air around the inverter is not blocked.
- ◆ Do not install in places where gasses or flammable substances may be present.

- ◆ Avoid electromagnetic interference that can compromise the correct operation of electronic equipment.
- ◆ It's recommended to install microinverter on structures underneath the photovoltaic modules so that they work in the shade.
- ◆ Use a mobile phone to check the Wi-Fi signal strength at the installation position. If the Wi-Fi signal is bad, try to install the microinverter in another position or move the Wi-Fi router.

Installation Steps

DANGER

- Before installation, check the unit to ensure the absence of any transport or handling damage, which could affect insulation integrity or safety clearances.
- Unauthorized removal of necessary protections, improper use, incorrect installation, and operation may lead to serious safety and shock hazards or equipment damage.
- Be aware that installation of this equipment includes the risk of electric shock.

Step 1. Install the bracket.

WARNING

- Choose the installation location carefully and adhere to specified cooling requirements. Micro-inverter should be installed in a suitable position with good ventilation and no direct sunshine.
- Please use your mobile phone to check the WiFi signal strength at the installation location, ensuring that the WiFi signal is at least two bars. If the WiFi signal is not good, please try installing the mini inverter in another location or moving the WiFi router.

➤ Balcony Installation

Choose a suitable position, fix the buffer strip on the railing, and then use stainless steel rolling strip to fix the bracket.

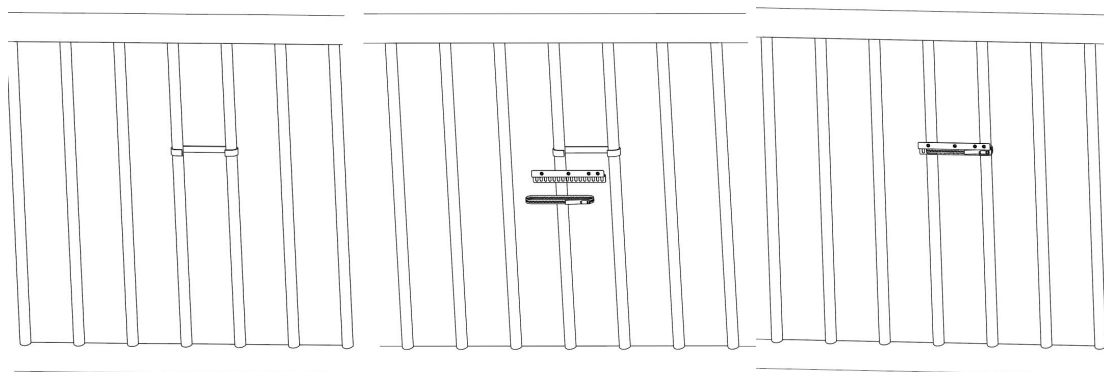

➤ Wall Installation

Fix the bracket to the wall with screws in a suitable position.

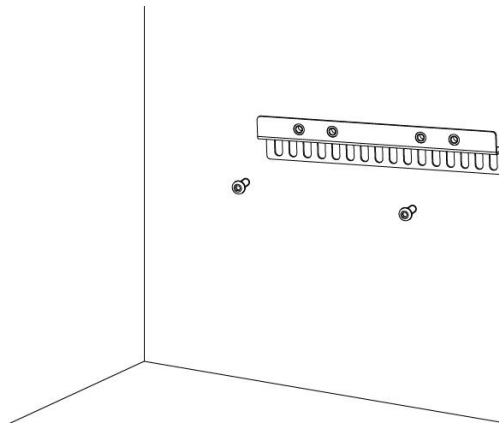

Step 2. Connect the ground cable



·Do not install the equipment in adverse environment conditions such as flammable, explosive, corrosive, extreme high or low temperature, and humid.

➤ Balcony Installation

Using two pairs of screws and nuts to fix the microinverter on the frame. Make sure that the label of microinverter should be upside.

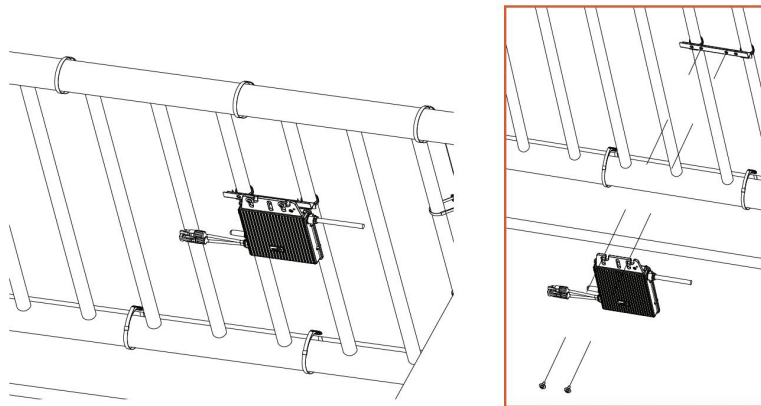

➤ Wall Installation

Using two pairs of screws and nuts to fix the microinverter on the frame. Make sure that the label of microinverter should be upside.

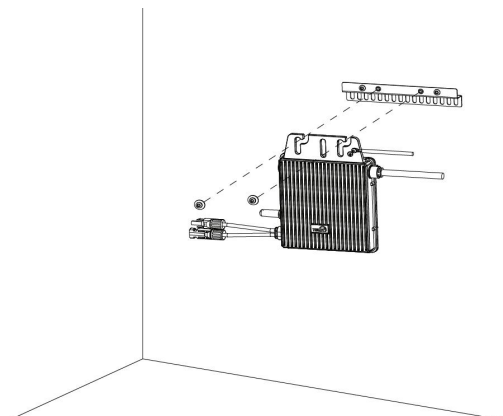

Step 3. Connect the ground cable.

⚠ WARNING

- Ensure that all the microinverters are well grounded.
- Use $\phi 6$ screw for the ground port.

Connect the ground cable to the enclosure of the microinverter.

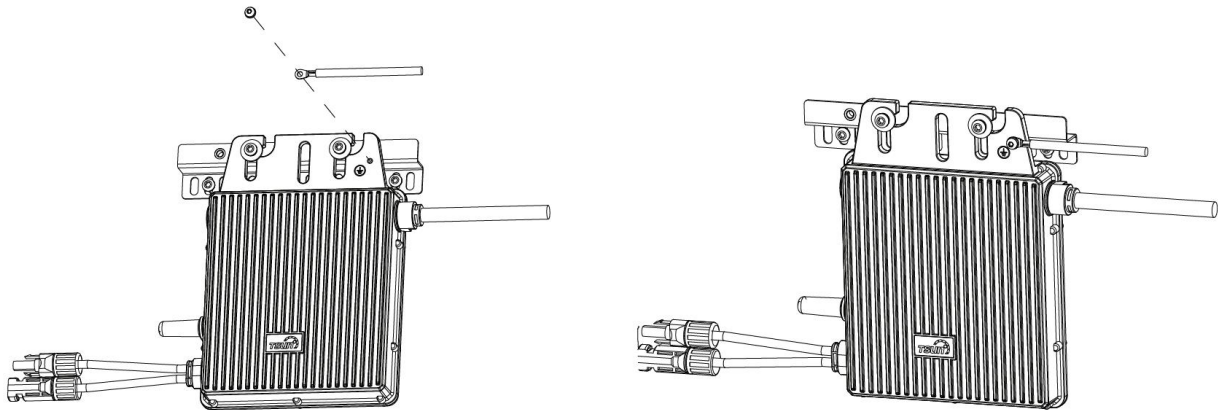

Step 4. Connect AC end cable

⚠ WARNING

- Ensure that all AC cables are correctly wired and that none of the wires are pinched or damaged.
- Use AWG 16 (1.5 mm²) cable for AC end cable.

⚠ CAUTION

·The AC connectors may be provided by different suppliers. The port definitions are subject to actual objects.

Separate the AC connector as shown below.



Get the AC cable through the shell of AC connector and connect the cable to the right port.

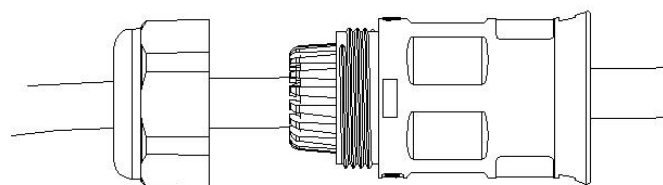

The definition of the port is shown below:

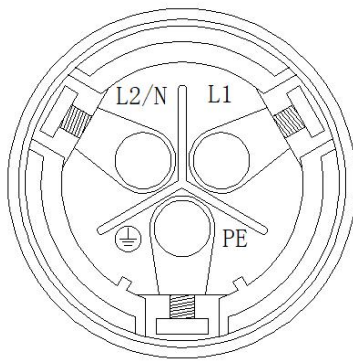

L:	Live	(Brown/Red)
N:	Neutral	(Blue/Black)
PE:	Ground	(Yellow-Green)

Reassemble the AC connector as shown below.

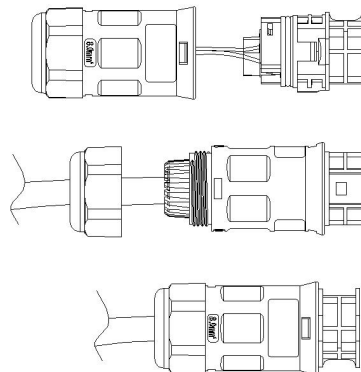

Plug the AC connector into the microinverter and connect the AC cable to the AC distribution box.

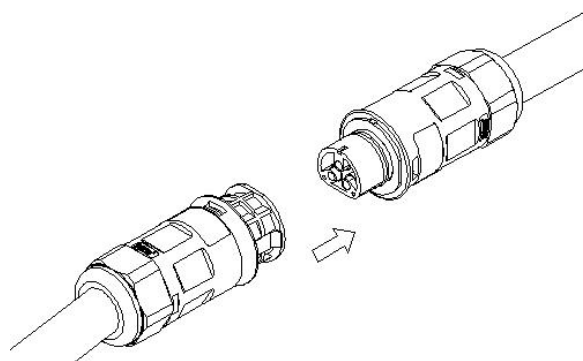

Step 5. Connect the DC cable

DANGER

·When the photovoltaic array is exposed to light, it provides a DC voltage to the inverter.

WARNING

·Ensure that all DC cables are correctly wired and that none of the wires are pinched or damaged.

·The maximum open circuit voltage of the PV module must not exceed the specified maximum input DC voltage of the TSOL microinverter.

CAUTION

·If the DC cable is too short for installation, use a DC Extension Cable to connect PV modules to the microinverter.

- Use MC4 compatible DC connectors in the inverter side of the DC extension cable, or get the DC connectors from TSUN.
- Contact PV module manufacturers for the requirements of the DC connectors in the module side of DC extension cable.

Install the PV modules and connect the DC cable to the microinverter.

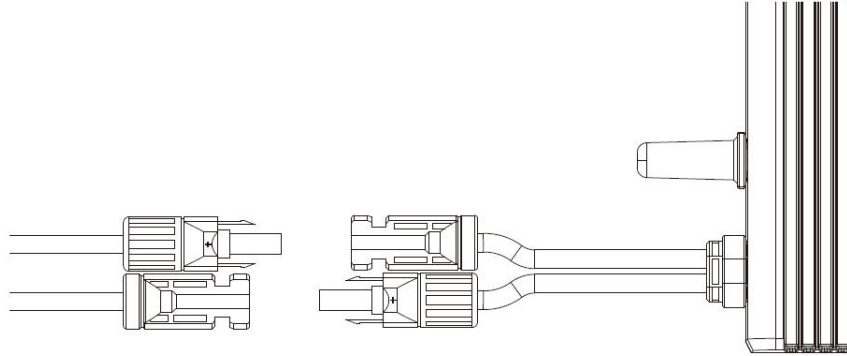

Step 6. Start the System

⚠ CAUTION

·Do not connect micro-inverters to the grid or energize the AC circuit(s) until you have completed all the installation procedures and have received prior approval from the electrical utility company.

While installation is all finished, After plugging in the socket and connecting to the power supply. Your system will start producing power after about a two-minute wait time.

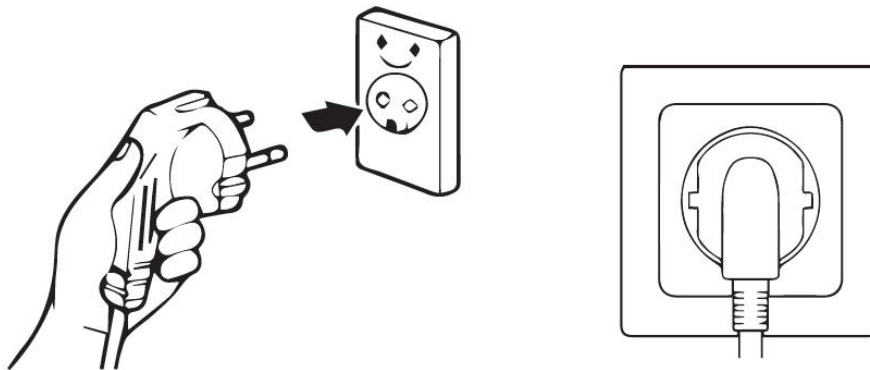

The LED will flash green and red at start-up. The definition of LED is shown below.

Status	Indicates
Flashing Green (0.2-0.8s)	Working normally
Flashing Red	Working abnormally
Solid Red	Fault

Remote Active Power Control

In some countries, it might be required that the generating plants should be equipped with a logic interface (input port) to cease the output of active power or limit active power to a regulated level. This logic input can be the RS485 port, Ethernet port, and so on. TSUN microinverter provides an extra power control device that contains an RS485 port for this remote active power control. For more information, refer to the “User Manual of TSUN power control device”.

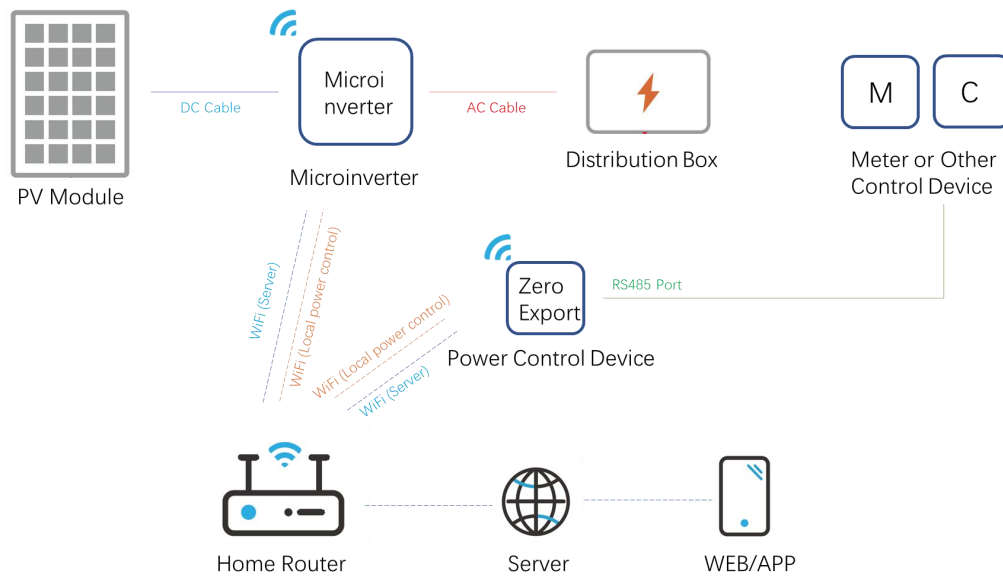

Self-Test Function for Italy

TSUN microinverter and TSUN monitoring system provide a Self-test function for the Italy market. For more information, refer to the “User Guidance of Self-test Function”.

Fault Code and Troubleshooting

Code	Fault Information	Troubleshooting
1	PV1VoltOver_Fault	Check the voltage of the PV module and make sure that the voltage is below the maximum DC input voltage of the microinverter.
2	PV2VoltOver_Fault	If this fault appears continuously, please contact the TSUN service.
3	PV1VoltLow_Fault	This warning mostly appears in the morning or at dusk. It's normal and will disappear automatically. If this warning appears in the daytime, please check the connection of the PV module.
4	PV2VoltLow_Fault	If this fault appears continuously, please contact the TSUN service.
5	PV1CurrOver_Fault	Disconnect the AC power to restart the microinverter.
6	PV2 CurrOver_Fault	If this fault appears continuously, please contact the TSUN service.
7	No Utility	The AC power grid is disconnected. Check the AC power grid. If this fault appears continuously, please contact the TSUN service.
8	GridVoltOverRating	The AC power grid is abnormal. This fault will disappear automatically when the AC power grid is normal. If this fault appears continuously, please contact the TSUN service.
9	GridVoltUnderRating	
10	GridFreqOverRating	
11	GridFreqUnderRating	
12	OverTemp	Check the installation of the microinverter. Make sure the microinverter has good heat dissipation. If this fault appears continuously, please contact the TSUN service.
13	GFDI_Fault	This is an internal fault. Disconnect the AC power to restart the microinverter. If this fault appears continuously, please contact the TSUN service.
14	Fault 01 - 08	Disconnect the AC power to restart the microinverter. If this fault appears continuously, please contact the TSUN service.

Maintenance Guide

Routine Maintenance

- ◆ Only authorized personnel are allowed to carry out the maintenance operations and are responsible for reporting any anomalies.
- ◆ Always use the personal protective equipment provided by the employer when carrying out maintenance.
- ◆ During normal operation, check that the environmental and logistic conditions are appropriate. Make sure that the conditions have not changed over time and that the equipment is not exposed to adverse weather conditions and has not been covered with foreign bodies.
- ◆ DO NOT use the equipment if any problems are found and restore the normal conditions after the fault has been corrected.
- ◆ Conduct an annual inspection on various components and clean the equipment with a vacuum cleaner or special brushes.
- ◆ Firmware version can be checked by using the monitoring system.
- ◆ Always de-energize the AC branch circuit before servicing.
- ◆ Do not attempt to dismantle the Micro-inverter or make any internal repairs! To preserve the integrity of safety and insulation, the Micro inverters are not designed to allow internal repairs!
- ◆ Maintenance operations must be carried out with the equipment disconnected from the grid (AC power switch off) and the photovoltaic modules shaded or isolated unless otherwise indicated.
- ◆ For cleaning, DO NOT use rags made of filamentary material or corrosive products that may corrode parts of the equipment or generate electrostatic charges.
- ◆ Avoid temporary repairs. All repairs should be carried out using only genuine spare parts.

Storage and Dismantling

- ◆ If the equipment is not used immediately or is stored for long periods, check whether it is correctly packed. The equipment must be stored in well-ventilated indoor areas that do not have characteristics that might damage the components of the equipment.
- ◆ Take a complete inspection when restarting after a long time or prolonged stop.
- ◆ Please dispose of the equipment properly after scrapping, as component parts are potentially harmful to the environment, following the regulations in force in the country of installation.

Recycling and Disposal

This device should not be disposed of as residential waste. A Microinverter that has reached the end of its life is not required to be returned to the dealer. Users must find an approved collection and recycling facility in the area.

Warranty Service

This Warranty is subject to the following conditions:

- ◆ The products must have been installed and correctly commissioned by an authorized and licensed installer. Proof may be required of correct commissioning of the Product (such as a certificate of compliance). Claims for failures due to incorrect installation or commissioning are not covered under this Warranty.
- ◆ Where a Product or part thereof is replaced or repaired under this Warranty, the balance of the original Warranty period will apply. The replacement product or part(s) do not carry a new voluntary warranty.
- ◆ The product must have its original serial number and rating labels intact and readable.
- ◆ This Warranty does not extend to any product that has been completely or partially disassembled or modified, except where such disassembly is carried out by TSUNESS
- ◆ The terms of this Warranty cannot be amended except in writing by one of our authorized officers.
- ◆ There must have been a commissioning report signed by the end user and the installer for product commissioning and handling instructions.

Exclusions

- (a) TSUNESS makes no warranties, either expressed or implied, orally, or in writing, concerning any other warranty coverage except those expressly stated in this limited Factory Warranty.
- (b) The Factory Warranty does not cover damages that occur due to:
 - Transport damage;
 - Installation or commissioning through any person who is not an Authorized, Certified Dealer;
 - Failure to observe the user manual, maintenance regulations, and intervals;
 - Modifications, changes, or attempted repairs, except as conducted by an Authorized Dealer;
 - Incorrect use or inappropriate operation;
 - Insufficient ventilation of the Covered Product;
 - Failure to observe the applicable safety regulations;
 - Force majeure.
- (c) This factory warranty does not cover cosmetic defects which do not directly influence energy production, or degrade form, fit, and function.
- (d) Claims that go beyond the scope of this limited Factory Warranty, in particular claims for

compensation for direct or indirect damages arising from the defective device, for compensation for costs arising from disassembly and installation, or loss of profits, are expressly NOT covered by this Factory Warranty.

(e) In no event will TSUNESS Co., Ltd be held responsible or liable for any personal injuries resulting from the use of the system, or for any other damages, whether direct, indirect, incidental, or consequential; even if TSUNESS Co., Ltd has been advised of such damages.

Distributor Responsibility

In the event of an equipment failure or fault, it is the Distributor's responsibility to work directly with the TSUNESS Service Centre to limit the return of non-faulty equipment. TSUNESS Service Centre will work with the Distributor to rectify the fault or fault message through telephone support or with direct PC links. Note: To qualify for further compensation and a replacement unit, the distributor/installer must first contact TSUNESS and fulfill the distributor's /installer's responsibilities under instruction.

Within the warranty period of the microinverter, the invoice and date of purchase are required for the service. Besides, the trademark on the product should be visible, otherwise, warranty is not available.

More information can be found in TSUN Warranty Policy.



TSUNESS Co., Ltd

 www.tsun-ess.com

 sales@tsun-ess.com

 No. 2266, Taiyang Road, Suzhou City,
Jiangsu Province, P.R. China